

Contur Modular Scaffold Technical Manual

Edition May, 2005

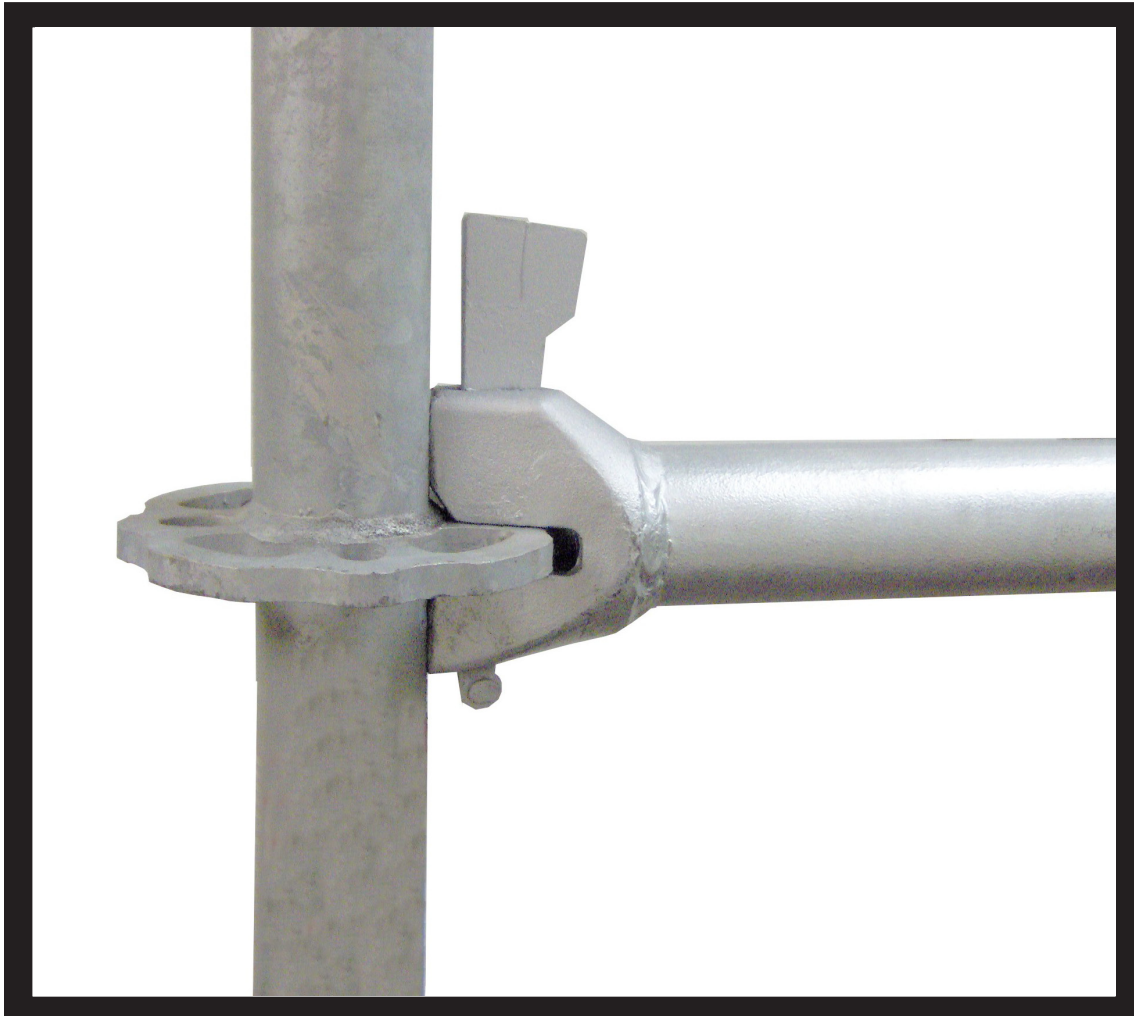

LL-204-70

BIL-JAX
A STEP ABOVE®

125 Taylor Parkway
Archbold, OH 43502
Ph. 800-537-0540
or 419-445-8915
Fax 419-445-0367

This manual is subject to periodic revision and updating. All photos / drawings are for illustration only. Always concerned with the improvement of the quality of this product, the manufacturer reserves the right to modify specifications without prior notice. Follow all applicable ANSI and OSHA Codes and Regulations for use of this equipment. Do not use this product in areas where user can come in contact with live power.

TABLE OF CONTENTS

Section A - Component Identification

Tubular Screw Jack _____	Page 1
Swivel Screw Jack _____	Page 1
8" Diameter Caster _____	Page 2
12" Diameter Caster _____	Page 2
Caster Adapter _____	Page 3
Vertical Standards (Bolted Inserts) _____	Page 4
Starter Collar _____	Page 4
Vertical Standards (Without Inserts) _____	Page 5
Insert With Spring Rivet _____	Page 6
Insert With Nut And Bolt _____	Page 6
Horizontals _____	Page 7
Horizontal Trusses _____	Page 8
Lattice Girders _____	Page 9
Horizontal Braces _____	Page 10
Vertical Braces _____	Page 11
Side Bracket (One Board) _____	Page 12
Side Brackets (Two and Three Board) _____	Page 12
Raised Steel Planks (Galvanized) _____	Page 13
Flush Steel Planks (Galvanized) _____	Page 14
Toeboards _____	Page 15
Stair Stringers (For Use With Raised Planks) _____	Page 16
Stair Stringers (For Use With Flush Planks) _____	Page 16
Stair Treads _____	Page 16
Access Ladder Units _____	Page 17
Access Ladder Bracket _____	Page 17
Base Beam (Boiler Applications) _____	Page 18
Throat Header (Boiler Applications) _____	Page 18
Support Frames (Boiler Applications) _____	Page 19
Support Frame Starter (Boiler Applications) _____	Page 19
Adj. Support Bracket (Boiler Applications) _____	Page 20
Saddle Brace (Boiler Applications) _____	Page 20
Storage Rack (Painted) _____	Page 21
Storage Rack Bin (Painted) _____	Page 21

Section B -

Allowable Component Loads

Capacity of Scaffold Joints _____	Page 1 and 2
Capacity of Tubular Screw Jack _____	Page 3
Capacity of Swivel Screw Jack _____	Page 4
Capacity of Casters _____	Page 5
Capacity of Vertical Standards _____	Page 6
Capacity of Suspended Scaffold Connection _____	Page 7
Capacity of Horizontals _____	Page 8
Capacity of Horizontal Trusses _____	Page 9
Capacity of Lattice Girders _____	Page 10
Capacity of Side Brackets _____	Page 11
Capacity of Steel Planks _____	Page 12

Section C - Assembly Details

Climbing Ladder Clamped to Vertical Standards _____	Page 1
Climbing Ladder Clamped to Horizontals _____	Page 2
Climbing Ladder - Rest Platforms _____	Page 3
Swivel Screw Jack _____	Page 3
Climbing Ladder - External Landing Platforms _____	Page 4
Typical Stair Tower With Post Supported Landings _____	Page 5
Typical Stair Tower With Side Bracket Supported Landings _____	Page 6
Steel Plank and Filler Chart - Horizontals (9-1/2" Wide Flush Plank) _____	Page 7
Steel Plank and Filler Chart - Horizontal Trusses (9-1/2" Wide Flush Plank) _____	Page 8
Steel Plank and Filler Chart - Horizontals (9" Wide Raised Plank) _____	Page 9
Steel Plank and Filler Chart - Horizontal Trusses (9" Wide Raised Plank) _____	Page 10

Section D - Bracing

Scaffold Bracing Pattern _____	Page 1
--------------------------------	--------

This Page Intentionally Left Blank

SECTION A

Component Identification

SECTION A

Introduction to Component Identification

This section contains system scaffold components illustrations, dimensions and weights to be used for visual part recognition and dimensional identification. The noted weights may be used for shipping weight and / or total scaffold weight calculations.

Systems Tubular Screw Jack

Rev.

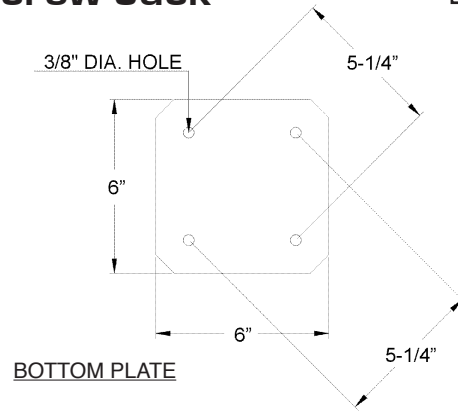
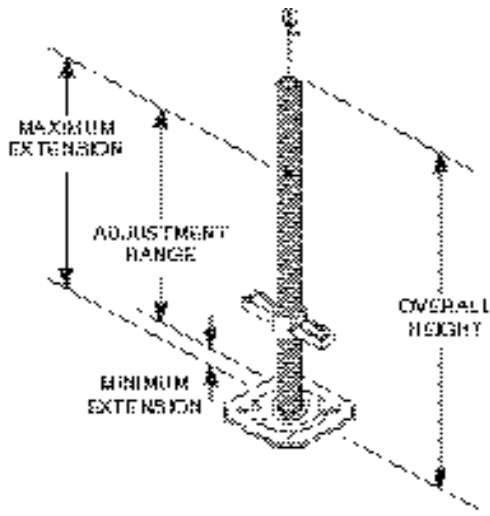

Part Number	0032-609
Maximum Extension	17"
Minimum Extension	2"
Adjustment Range	15"
Overall Height	24"
Weight Galvanized	8 lbs.

Systems Swivel Screw Jack

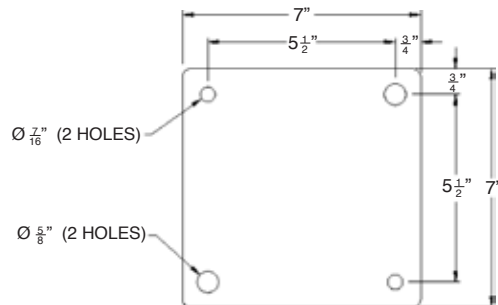
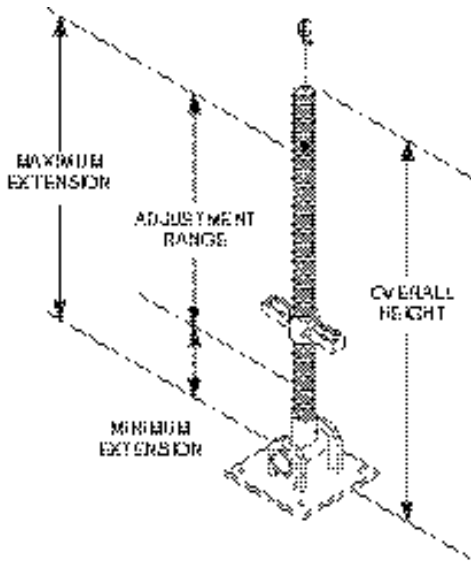

Part Number	0032-135
Maximum Extension	22"
Minimum Extension	8"
Adjustment Range	14"
Overall Height	28"
Weight Galvanized	15 lbs.

Systems 8" Diameter Caster

Rev.

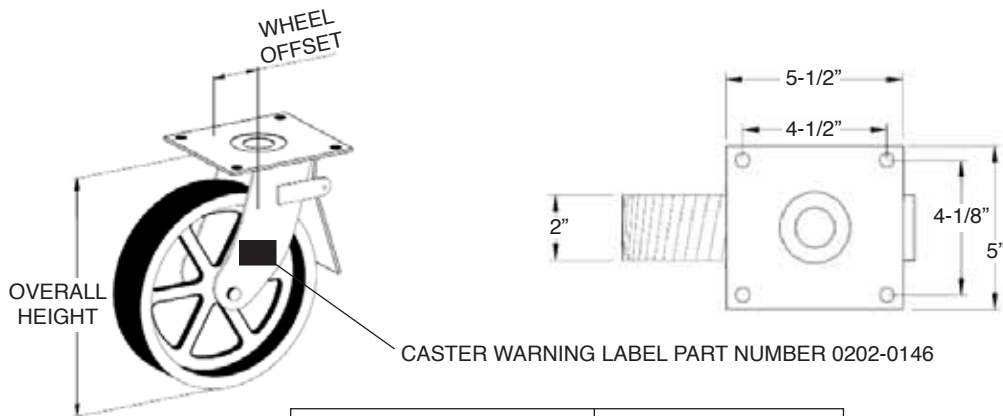

Part Number	0026-001
Wheel Style	Steel
Wheel Offset	2"
Overall Height	9-1/2"
Wheel Thickness	2"
Weight	15.4 lbs.

Systems 12" Diameter Caster

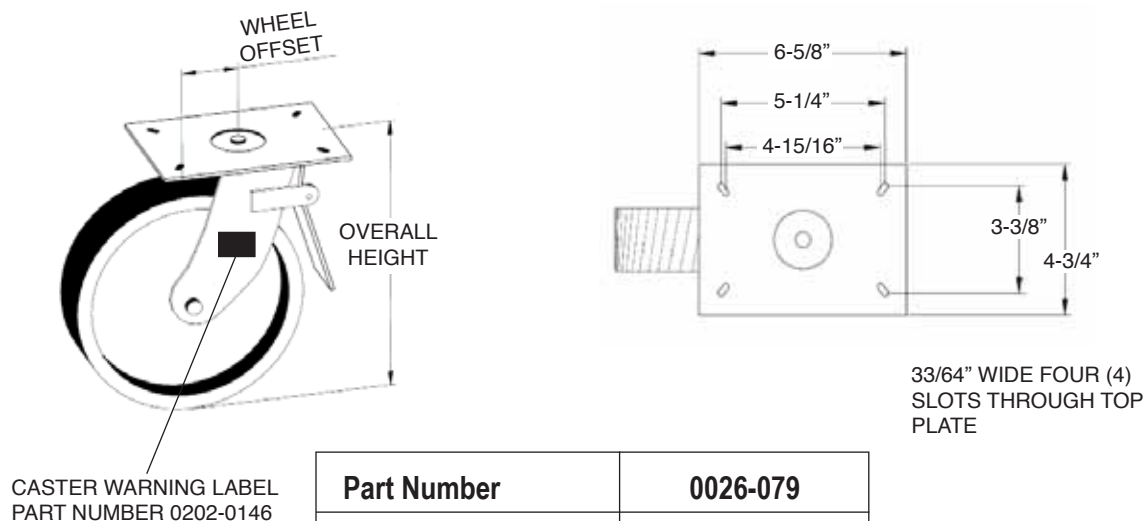

Part Number	0026-079
Wheel Style	Steel
Wheel Offset	2-7/8"
Overall Height	14-1/2"
Wheel Thickness	2-5/8"
Weight	36.7 lbs.

Systems Caster Adapter

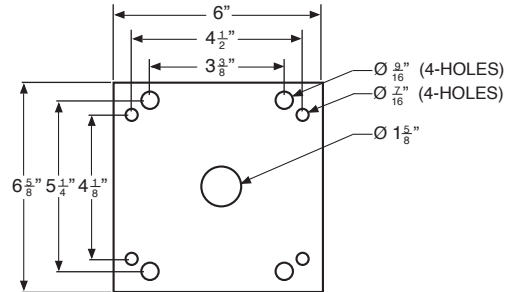
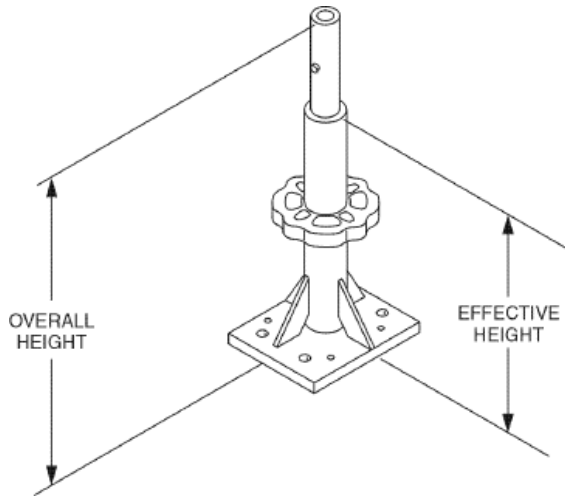

Part Number	0257-13
Effective Height	10"
Overall Height	15-29/32"
Weight Galvanized	5.6 lbs.

Systems Vertical Standards (Bolted Inserts)

Rev.

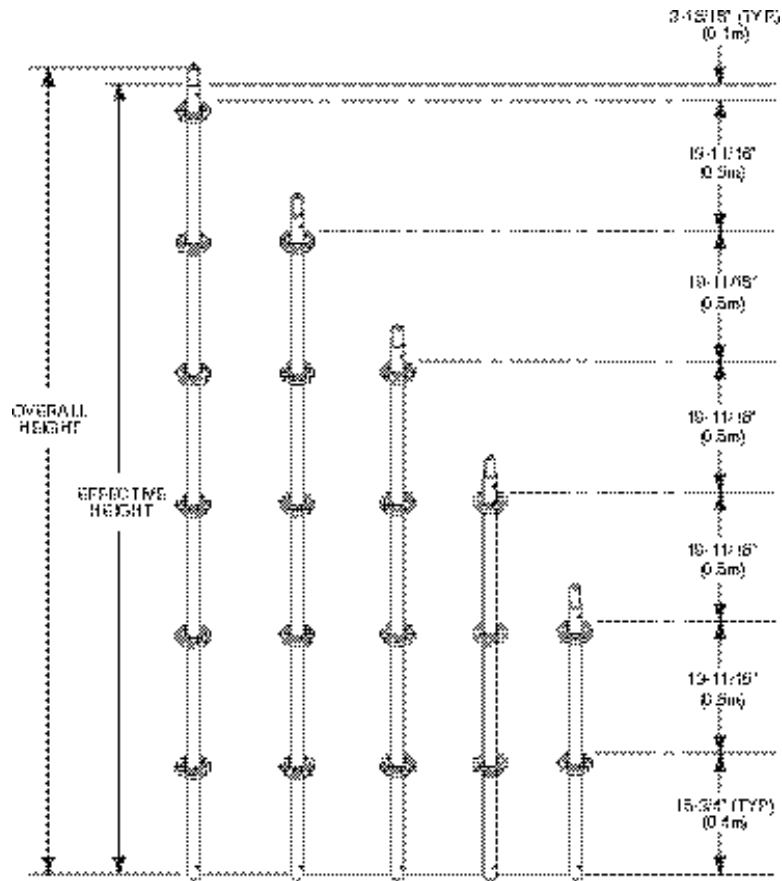

Part Number	C257-22-130		C257-22-125		C257-22-120		C257-22-115		C257-22-110		C257-22-105	
Units	metric	imperial	metric	imperial	metric	imperial	metric	imperial	metric	imperial	metric	imperial
Effective Ht.	3.0m	118"	2.5m	98-13/32"	2.0m	78-3/4"	1.5m	59"	1.0m	39-13/32"	0.5m	19-11/16"
Overall Ht.	3.15m	124"	2.65m	104"	2.15m	84-21/32"	1.65m	64-21/32"	1.15m	45-9/32"	0.65m	25-5/8"
Weight Galv.	13.64kg	31 lbs.	11.8kg	26 lbs.	9.6kg	21 lbs.	7.3kg	16 lbs.	5kg	11 lbs.	2.5kg	5.5 lbs.

Systems Starter Collar

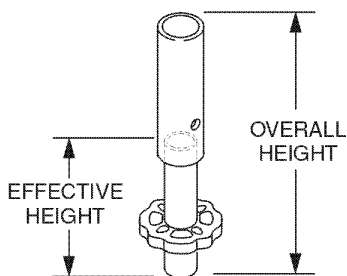

Part Number	C257-01-100	
Units	metric	imperial
Effective Height	16cm	6-19/64"
Overall Height	33cm	13"
Weight Galvanized	2.10kg	4.63 lbs.

Systems Vertical Standards (Without Inserts)

Rev.

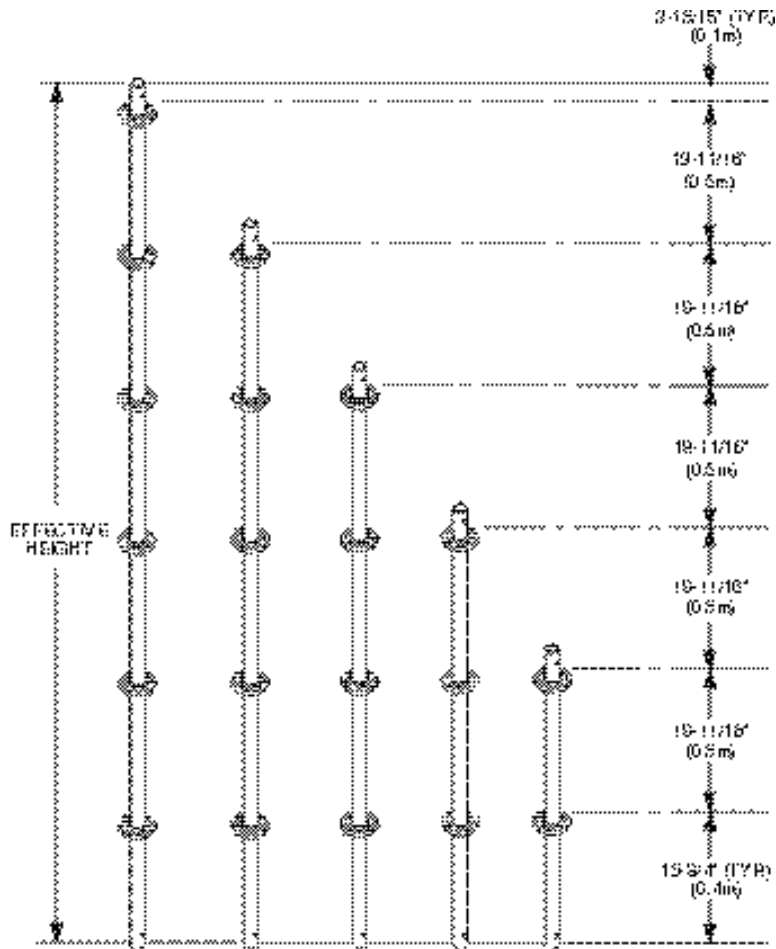

Part Number	C257-19-130		C257-19-125		C257-19-120		C257-19-115		C257-19-110		C257-19-105	
Units	metric	imperial	metric	imperial	metric	imperial	metric	imperial	metric	imperial	metric	imperial
Effective Ht.	3.0m	118"	2.5m	98-7/16"	2.0m	78-3/4"	1.5m	59"	1.0m	39-3/8"	0.5m	19-11/16"
Weight Galv.	13.18kg	29lbs.	10.9kg	24 lbs.	8.64kg	19 lbs.	6.4kg	14 lbs.	4.1kg	9 lbs.	2.05kg	4.5 lbs.

Systems Insert With Spring Rivet

Rev.

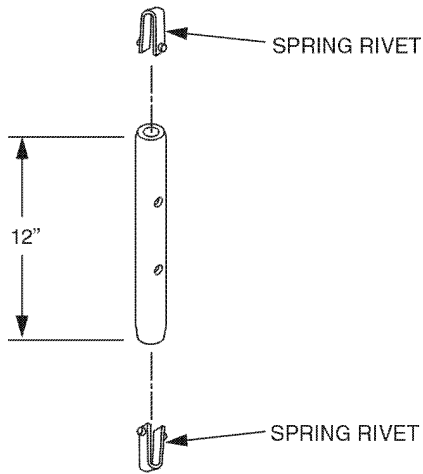

Part Number 0007-169

Weight Galv. 2 lbs.

Systems Insert With Nut And Bolt

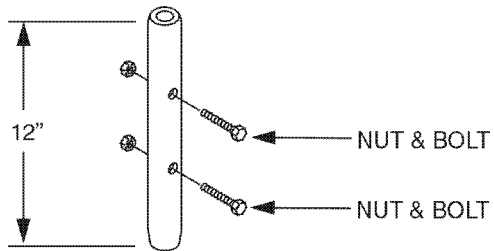

Part Number C007-176

Weight Galv. 2 lbs.

Systems Horizontals

Rev.

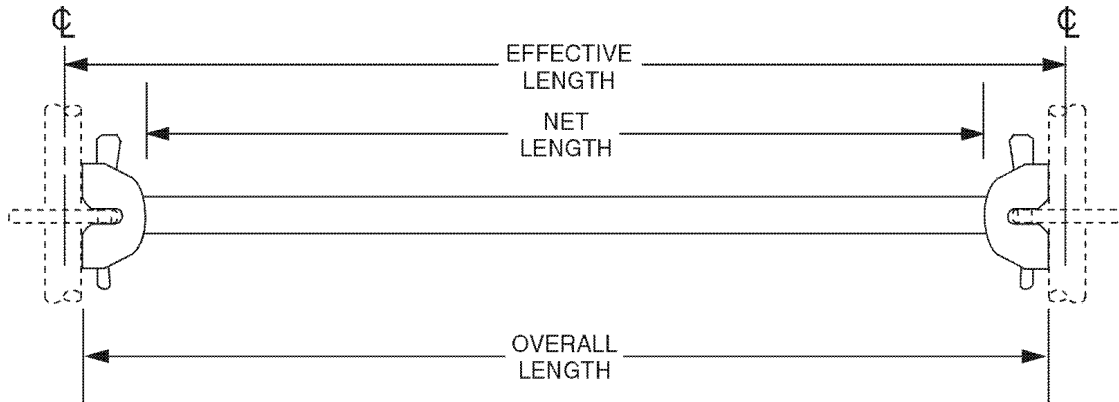

Part Number	Effective Length	Net Length	Overall Length	Weight Galv.
C257-02-2024	2'	18"	22"	7 lbs.
C257-02-107	2' 3-19/32"	21-19/32"	25-23/32"	7.5 lbs.
C257-02-2030	2' 6"	24"	28"	8 lbs.
C257-02-2036	3'	30"	34"	9 lbs.
C257-02-2042	3' 6"	36"	40"	10 lbs.
C257-02-2048	4'	42"	46"	11 lbs.
C257-02-2060	5'	54"	58"	13 lbs.
C257-02-2072	6'	66"	70"	15 lbs.
C257-02-2084	7'	78"	82"	17 lbs.
C257-02-2096	8'	90"	94"	19 lbs.
C257-02-2108	9'	102"	106"	21 lbs.
C257-02-2120	10'	114"	118"	23 lbs.

Systems Horizontal Trusses

Rev.

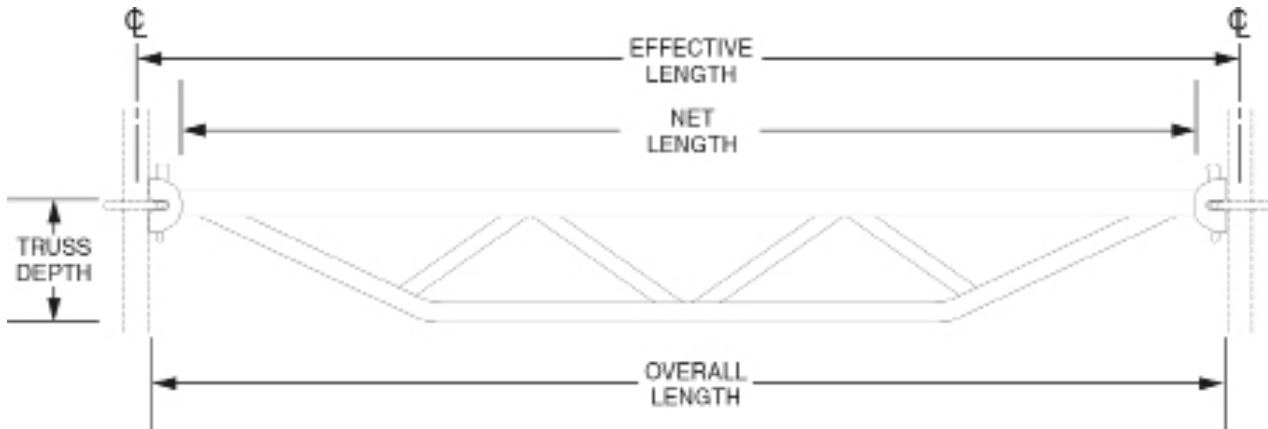

Part Number	0257-04-2060	0257-04-2072	0257-04-2084	0257-04-2096	0257-04-2108	0257-04-2120
Effective Length	5'	6'	7'	8'	9'	10'
Net Length	54"	66"	78"	90"	102"	114"
Truss Depth	10-11/16"	10-11/16"	10-11/16"	10-11/16"	10-11/16"	10-11/16"
Overall Length	58"	70"	82"	94"	106"	118"
Weight Galv.	lbs.	lbs.	lbs.	lbs.	lbs.	lbs.

Systems Lattice Girders

Rev.

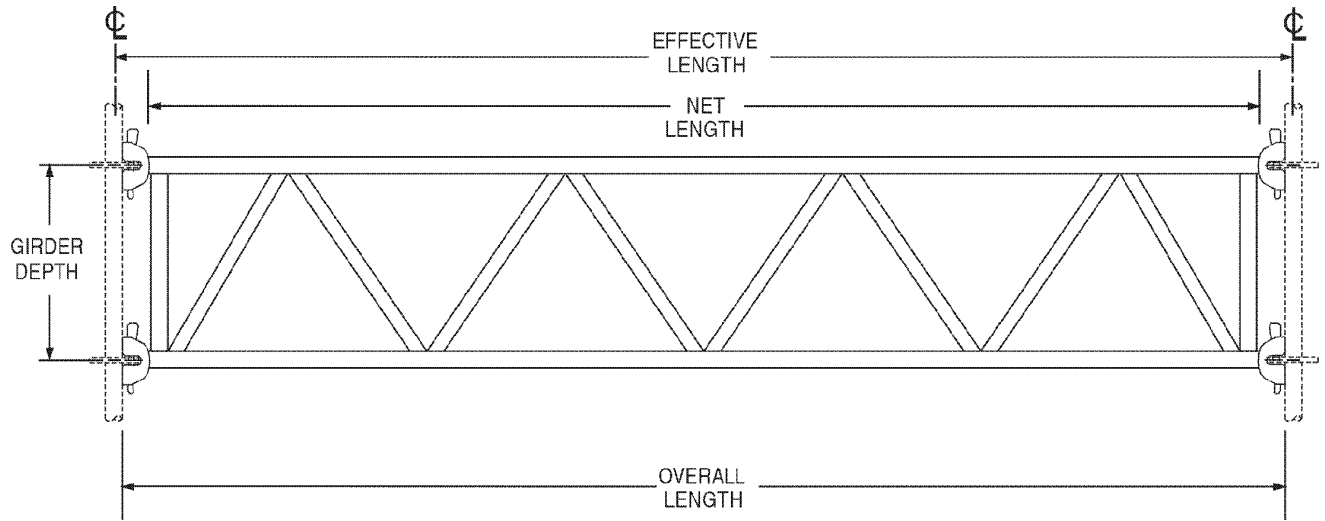

Part Number	0257-23-2144	0257-23-2168	0257-23-2192	0257-23-2216	0257-23-2240
Effective Length	12'	14'	16'	18'	20'
Net Length	150"	162"	186"	210"	234"
Girder Depth	18-13/32"	18-13/32"	18-13/32"	18-13/32"	18-13/32"
Overall Length	142"	166"	190"	214"	238"
Weight Galv.	75 lbs.	107 lbs.	120 lbs.	130 lbs.	145 lbs.

Systems Horizontal Braces

Rev.

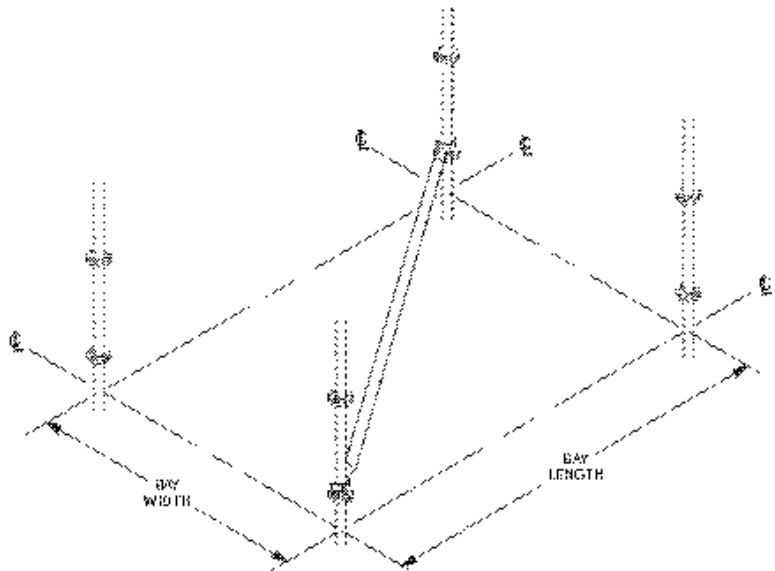

Part Number	Bay Width x Bay Length	Tube Length	Overall Length	Weight Galv.
0250-06-2036034	3' x 7'	89-1/16"	95-1/16"	14 lbs.
0250-06-2036096	3' x 8'	100-1/4"	106-1/4"	15 lbs.
0250-06-2036108	3' x 9'	111-1/2"	117-1/2"	17.5 lbs.
0250-06-2036120	3' x 10'	123"	129"	19 lbs.
0250-06-2042084	42" x 7'	91-5/8"	97-5/8"	14.5 lbs.
0250-06-2042096	42" x 8'	104-25/32"	110-25/32"	16.5 lbs.
0250-06-2042108	42" x 9'	113-9/16"	121-9/16"	18 lbs.
0250-06-2042120	42" x 10'	124-13/16"	134-13/16"	20 lbs.
0250-06-2048084	4' x 7'	94-15/32"	100-15/32"	15 lbs.
0250-06-2048096	4' x 8'	105-1/32"	111-1/32"	17 lbs.
0250-06-2148108	4' x 9'	115-29/32"	121-29/32"	18.5 lbs.
0250-06-2148120	4' x 10'	126-15/16"	132-15/16"	20 lbs.
0250-06-2060084	5' x 7'	100-15/16"	106-15/16"	15 lbs.
0250-06-2060096	5' x 8'	110-15/16"	116-15/16"	17.5 lbs.
0250-06-2060108	5' x 9'	121-1/4"	127-1/4"	19.5 lbs.
0250-06-2060120	5' x 10'	131-7/8"	137-7/8"	21 lbs.
0250-06-2072084	6' x 7'	108-11/32"	114-11/32"	17.5 lbs.
0250-06-2072096	6' x 8'	117-23/32"	123-23/32"	19 lbs.
0250-06-2072108	6' x 9'	127-5/8"	133-5/8"	20 lbs.
0250-06-2072120	6' x 10'	137-21/32"	143-21/32"	22 lbs.
0250-06-2084084	7' x 7'	116-1/2"	122-1/2"	18.5 lbs.
0250-06-2084108	7' x 9'	134-17/32"	140-17/32"	21.5 lbs.
0250-06-2084120	7' x 10'	146-15/32"	152-15/32"	23.5 lbs.
0250-06-2108108	9' x 9'	150-7/16"	156-7/16"	24 lbs.
0250-06-2108120	9' x 10'	159-5/32"	165-5/32"	25.5 lbs.
0250-06-2120120	10' x 10'	167-13/32"	173-13/32"	26 lbs.

Systems Vertical Braces

Rev.

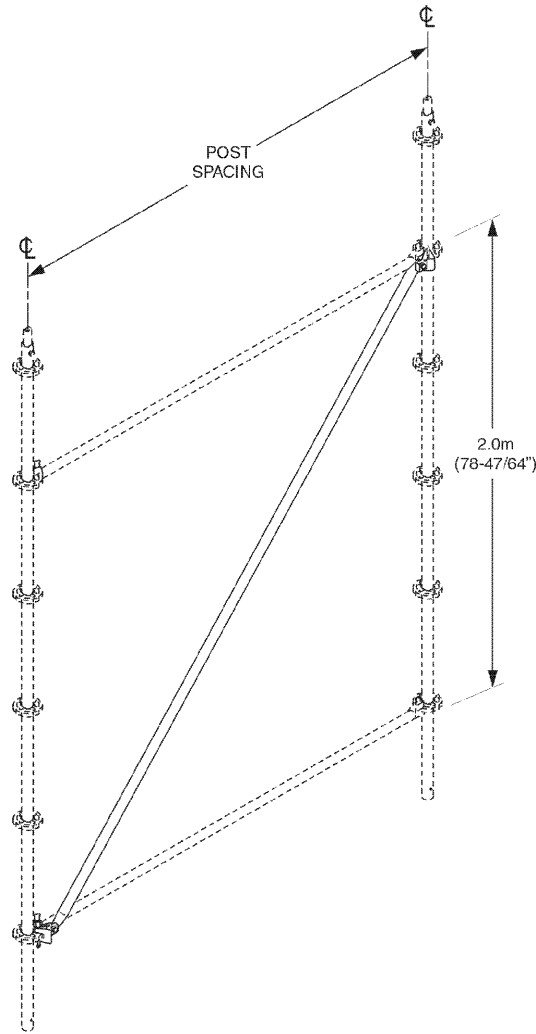

Part Number	Post Spacing	Tube Length	Vertical Distance	Weight Galv.
C257-05-303620	3'	83"	2.0m 78-3/4"	15.3 lbs.
C257-05-304220	3' 6"	87"	2.0m 78-3/4"	16 lbs.
C257-05-304820	4'	88-1/2"	2.0m 78-3/4"	16.5 lbs.
C257-05-306020	5'	94-13/16"	2.0m 78-3/4"	17.3 lbs.
C257-05-307220	6'	102"	2.0m 78-3/4"	18.5 lbs.
C257-05-308420	7'	112"	2.0m 78-3/4"	20.17 lbs.
C257-05-309620	8'	119"	2.0m 78-3/4"	21.13 lbs.
C257-05-310820	9'	128-13/32"	2.0m 78-3/4"	23 lbs.
C257-05-312020	10'	138"	2.0m 78-3/4"	24.5 lbs.

Systems Side Bracket (One Board)

Rev.

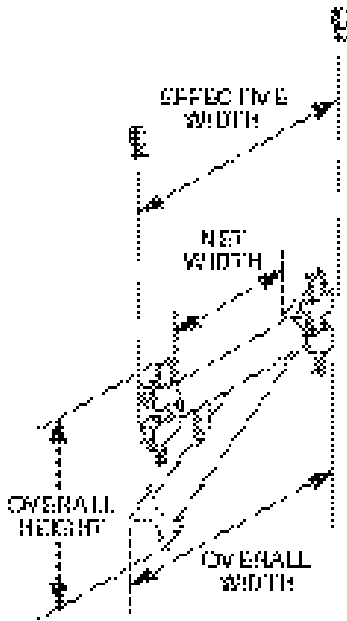

Part Number	0257-07
Description	One Board
Effective Width	15-3/4"
Net Width	9-3/4"
Overall Width	13-27/32"
Overall Height	10-13/32"
Weight Galvanized	10 lbs.

Systems Side Brackets (Two and Three Board)

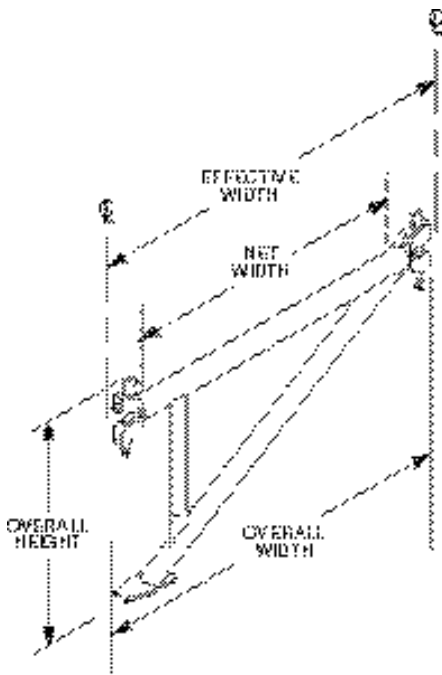

Part Number	0257-08	0257-09
Description	Two Board	Three Board
Effective Width	27-9/16"	36"
Net Width	21-9/16"	30"
Overall Width	25-21/32"	34"
Overall Height	19-21/32"	19.65"
Weight Galvanized	15 lbs.	20 lbs.

Systems Raised Steel Planks (Galvanized)

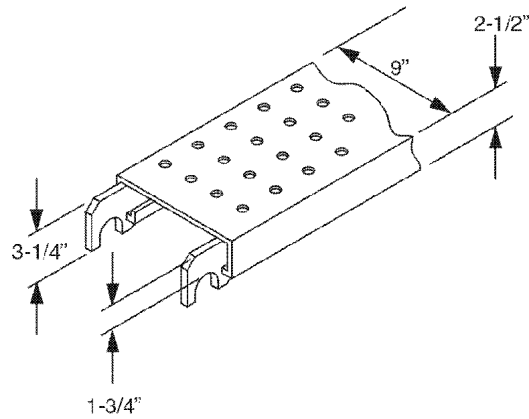
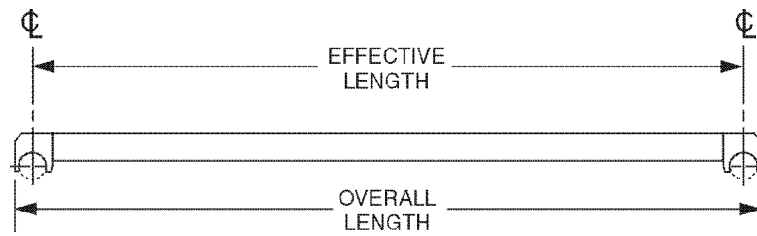

Part Number	Effective Length	Overall Length	Weight Galv.
C056-01-03	3'	34"	15 lbs.
C056-01-04	4'	51"	19.3 lbs.
C056-01-05	5'	63"	23.5 lbs.
C056-01-06	6'	75"	27.7 lbs.
C056-01-07	7'	87"	32 lbs.
C056-01-08	8'	99"	36 lbs.
C056-01-09	9'	111"	40.2 lbs.
C056-01-10	10'	123"	44.4 lbs.

Systems Flush Steel Planks (Galvanized)

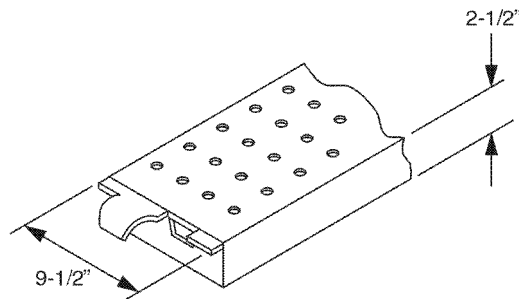
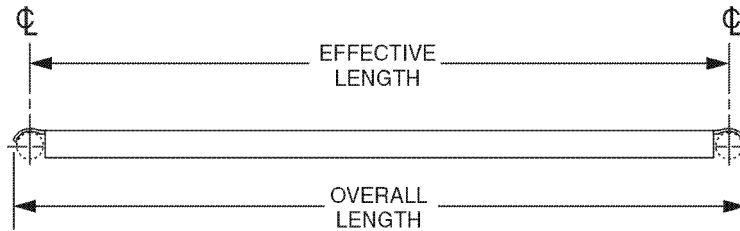

Part Number	Effective Length	Overall Length	Weight Galv.
0056-07-03	3'	38-5/16"	18 lbs.
0056-07-04	4'	50-5/16"	24 lbs.
0056-07-05	5'	62-5/16"	28 lbs.
0056-07-06	6'	74-5/16"	32 lbs.
0056-07-07	7'	86-5/16"	36 lbs.
0056-07-08	8'	98-5/16"	40 lbs.
0056-07-09	9'	110-5/16"	44 lbs.
0056-07-10	10'	120-5/16"	48 lbs.

Systems Toeboards

This Page Intentionally Left Blank

Systems Stair Stringers For Use With Raised Planks

Rev.

Part Number	Side	Bay Size	Overall Length	No. of Steps	Weight Galv.
0042-229L	Left	7' x 2.0m	117-1/32"	8	60 lbs.
0042-229R	Right	7' x 2.0m	117-1/32"	8	60 lbs.
0042-171L	Left	8' x 2.0m	126-1/16"	10	70 lbs.
0042-171R	Right	8' x 2.0m	126-1/16"	10	70 lbs.

NOTE: 2.0m = 6' 6" (approximate)

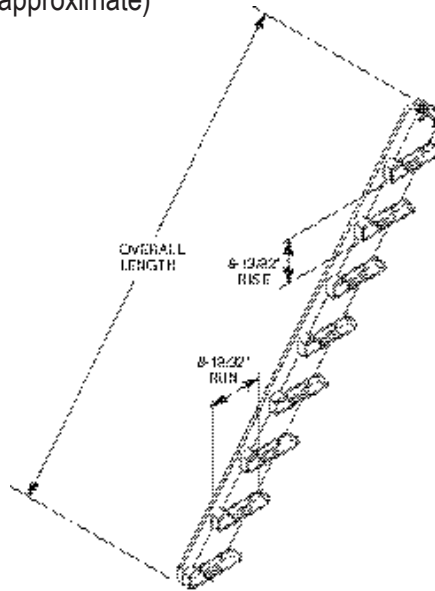

Systems Stair Stringers For Use With Flush Planks

Part Number	Side	Bay Size	Overall Length	No. of Steps	Weight Galv.
0088-081	Left	7' x 2.0m	117-1/32"	8	60 lbs.
0088-082	Right	7' x 2.0m	117-1/32"	8	60 lbs.
0088-074	Left	8' x 2.0m	126-1/32"	9	66 lbs.
0088-075	Right	8' x 2.0m	126-1/32"	9	66 lbs.

NOTE: 2.0m = 6' 6" (approximate)

Systems Stair Treads

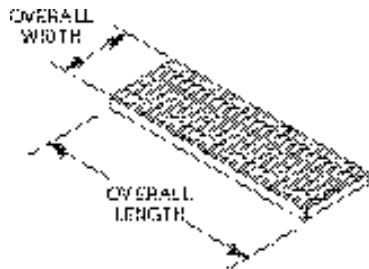

Part Number	Bay Size	Overall Length	Overall Width	Weight Galv.
0088-078-04	48" Bay	36"	11-3/4"	13 lbs.
0088-078-0306	42" Bay	29-1/4"	11-3/4"	13 lbs.

Access Ladder Units

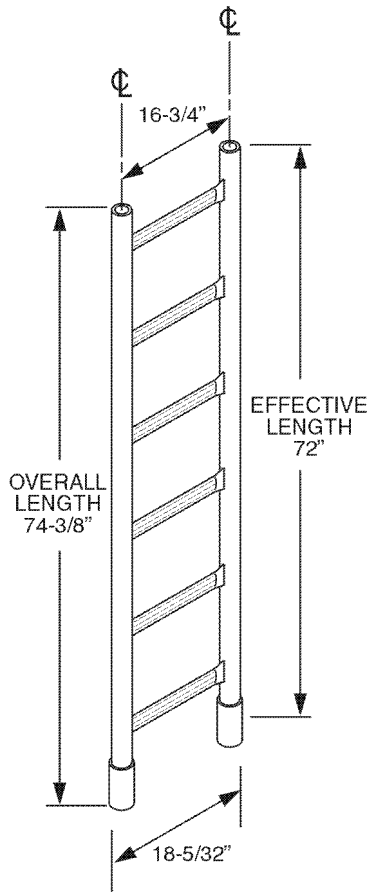

Part Number 0004-0582
Weight Galv. 18 lbs.

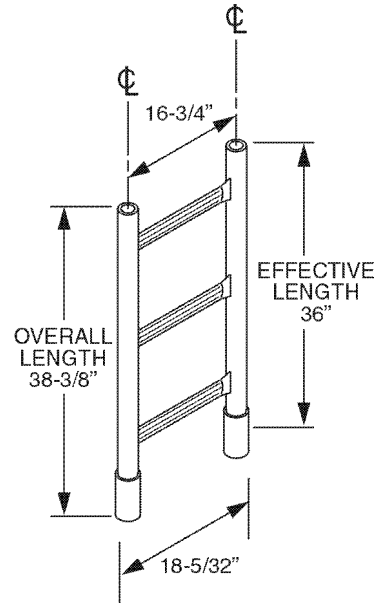

Part Number 0004-0581
Weight Galv. 9.5 lbs.

Access Ladder Bracket



Part Number 0063-0570
Weight Galv. 5.5 lbs.

Systems Base Beam (Boiler Applications)

Rev.

NOTE:
ENDS OF THROAT HEADER ARE
TAPERED TO FIT 55° SLOPED
BOILER WALLS AT BASE.

Part Number 0259-04-06BK
Weight Galv. 115 lbs.

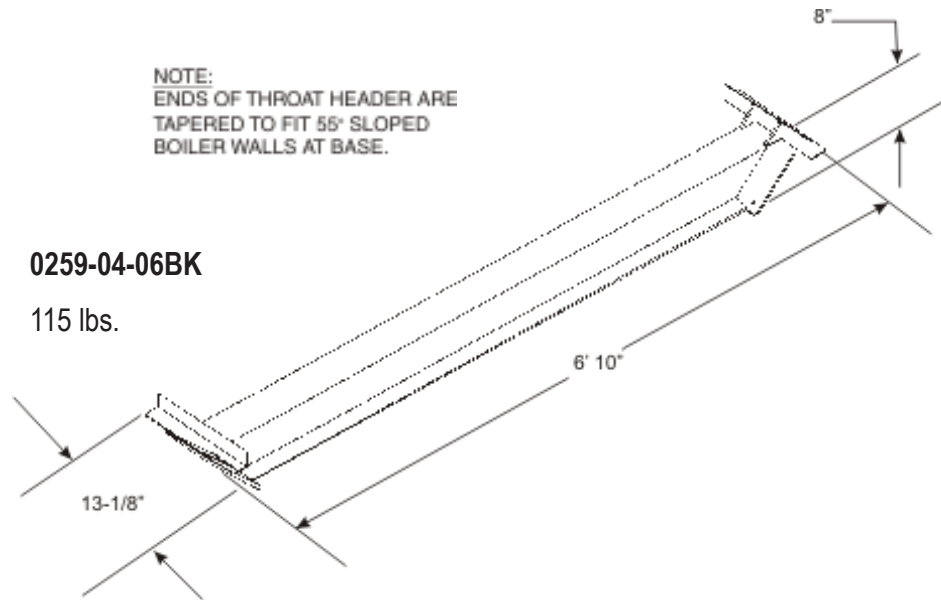

Systems Throat Header (Boiler Applications)

NOTE:
ENDS OF THROAT HEADER ARE
TAPERED TO FIT 55° SLOPED
BOILER WALLS AT BASE.

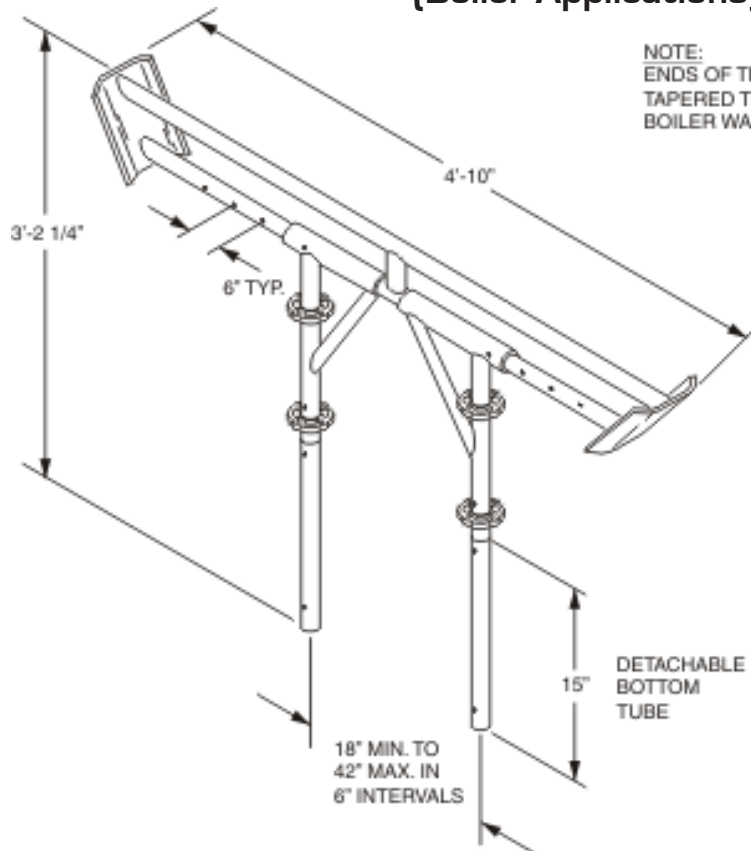

Part Number 0253-47BK
Weight Galv. 47 lbs.

Systems Support Frames (Boiler Applications)

Rev.

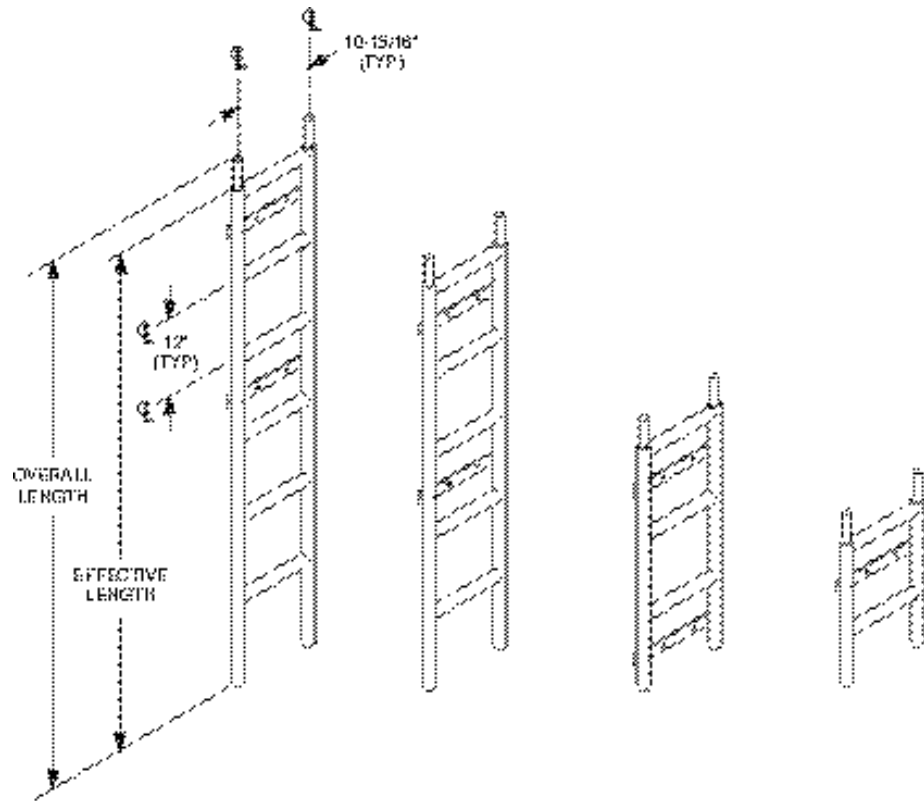

Part Number	Effective Length	Overall Length	Weight
0259-03-01BK	12-1/8"	18-1/8"	12.2 lbs.
0259-03-03BK	36"	42"	26.2 lbs.
0259-03-05BK	60"	66"	37.8 lbs.
0259-03-06BK	72"	78"	43.5 lbs.

Systems Support Frame Starter (Boiler Applications)

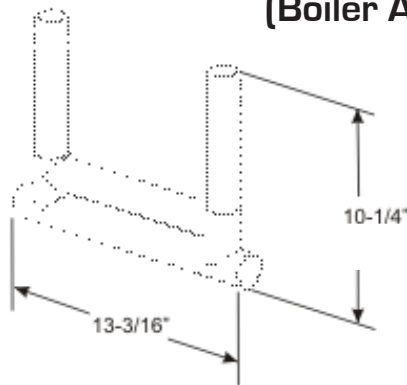

Part Number 0259-02BK
 Weight Galv. 7.4 lbs.

Systems Adjustable Support Bracket (Boiler Applications)

Rev.

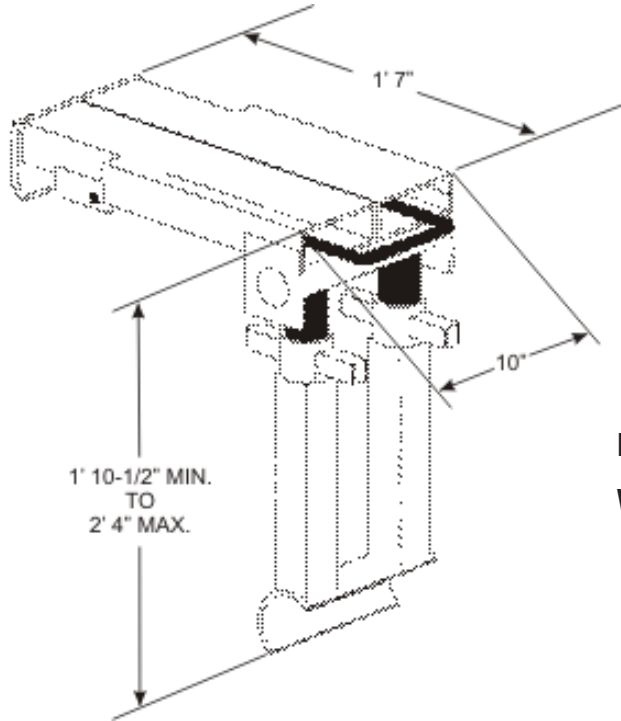

Part Number 0259-05BK

Weight Galv. 53 lbs.

Systems Saddle Brace (Boiler Applications)

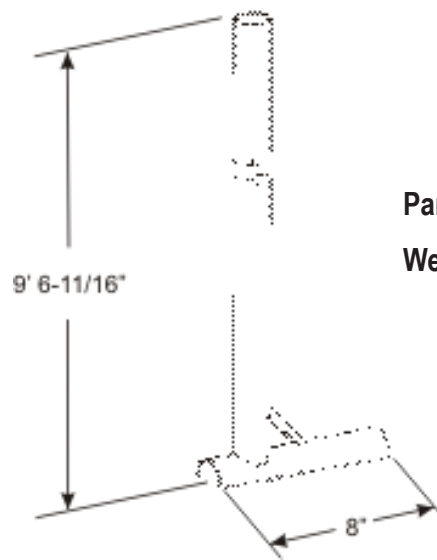

Part Number 0259-01BK

Weight Galv. 21 lbs.

Rev.

Systems Storage Rack (Painted)

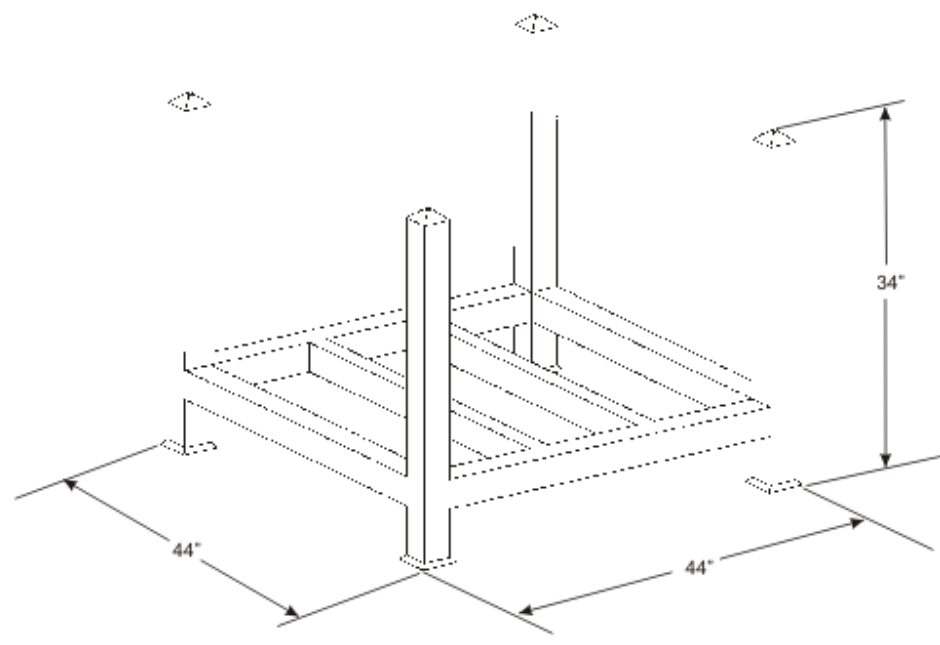

Part Number 0110-209
Weight Galv. 120 lbs.

Systems Storage Rack Bin (Painted)

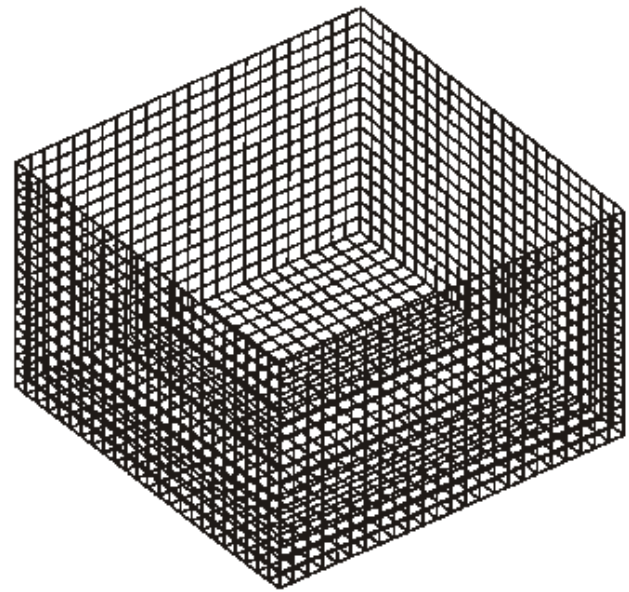

Part Number 0110-211
Weight Galv. 125 lbs.

This Page Intentionally Left Blank

SECTION B

Allowable Component Loads

SECTION B

Introduction to Allowable Component Loads

This section contains illustrations and load ratings for the various systems scaffold components. The load ratings are based on the capacity of the individual components only. Refer to Section D and warning on inside front cover before computing the scaffold loads.

Allowable loads specified in this section include safety factors required by Federal OSHA.

When designing scaffolds with unique configurations or special loading conditions, consult with bil-jax engineering department or a professional structural engineer prior to design finalization.

Capacity of Scaffold Joint

Rev.

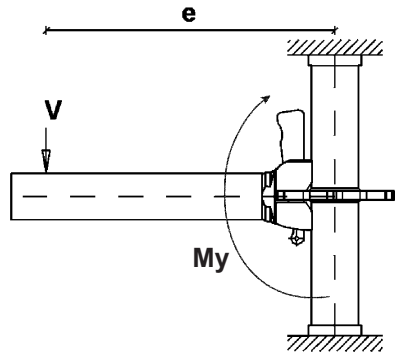

Moment of Resistance of Joint

$$M_y = V * e$$

Working Moment: $M_y = \pm 36.25 \text{ kNcm}$
 ($\pm 3,208 \text{ lbs. in.}$)

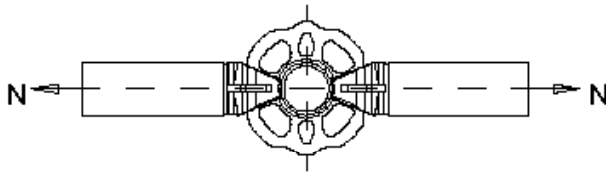

Normal Load on Joint

Working Load: $N = \pm 12.50 \text{ kN}$
 ($\pm 2,810 \text{ lbs.}$)

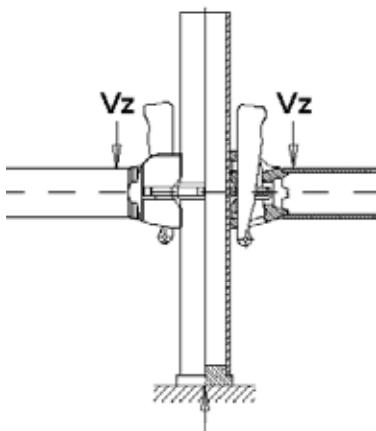

Vertical Load on Rosette

per wedge connection:

Breaking Load:

max $V_z = \pm 47.0 \text{ kN}$ ($\pm 10,566 \text{ lbs.}$)

Working Load: $V_z = \pm 11.75 \text{ kN}$ ($\pm 2,691 \text{ lbs.}$)

allowable load on rosette:

Breaking Load: $\Sigma V_z = \pm 198.0 \text{ kN}$ ($\pm 44,510 \text{ lbs.}$)

Working Load: $\Sigma V_z = \pm 49.5 \text{ kN}$ ($\pm 11,128 \text{ lbs.}$)

Rated For Scaffold Use

Capacity of Scaffold Joint

Rev.

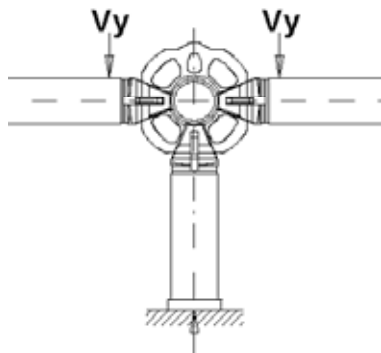

Horizontal Load on Rosette

per wedge connection:

Breaking Load:

max Vy = ± **18.8 kN** (± 4,226 lbs.)

Working Load: Vy = ± **4.7 kN** (± 1,057 lbs.)

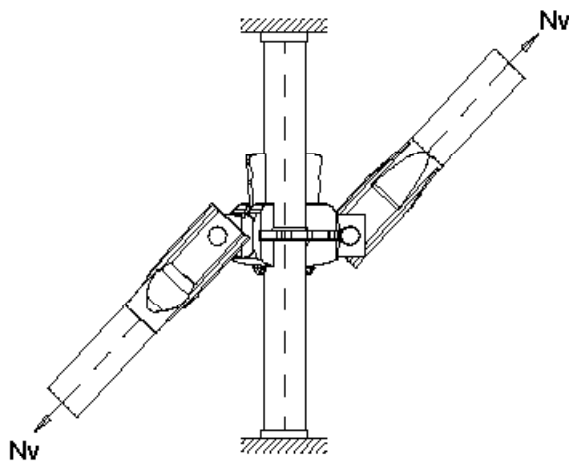

Diagonal Load

(tensible force)

Breaking Load:

max Nv = + **40.2 kN** (+ 9,037 lbs.)

Working Load Nv = + **10.1 kN** (+ 2,270 lbs.)

maximal forces of pressure are listed in Table 1.

Table 1: Diagonal Load (forces of pressure)

Height (m)	Length (m)	max Nv (kN)
2.00	0.74 (2.46 ft.)	- 9,3 (2195 lbs.)
2.00	1.06 (3.48 ft.)	- 7,8 (1747 lbs.)
2.00	1.50 (4.9 ft.)	- 6,0 (1344 lbs.)
2.00	2.00 (6.5 ft.)	- 4,8 (1075 lbs.)
2.00	2.50 (8.2 ft.)	- 4,0 (896 lbs.)
2.00	3.00 (9.84 ft.)	- 3,3 (739 lbs.)

Rated For Scaffold Use

Technical Manual

Section B

Page 2 of 12

**Contur Modular Scaffold
Component Allowable Loads**

BIL-JAX[®]

Capacity of Systems Tubular Screw Jack (For Variable Jack Extensions)

Rev.

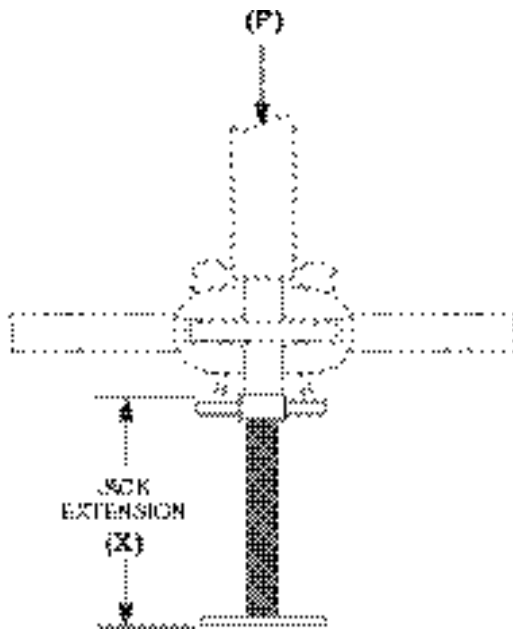

Part Number 0032-609

Weight Galv. 7 lbs.

Jack Extension (X)		Maximum Allowable Compressive Load (P)	
Metric (m)	Imperial (in.)	Metric (kn)	Imperial (lbs.)
0.43m	17"	18kn	4,000 lbs.
0.35m	14"	31kn	7,000 lbs.
0.30m	12"	33kn	7,500 lbs.

Rated For Scaffold Use

Capacity of Systems Swivel Screw Jack

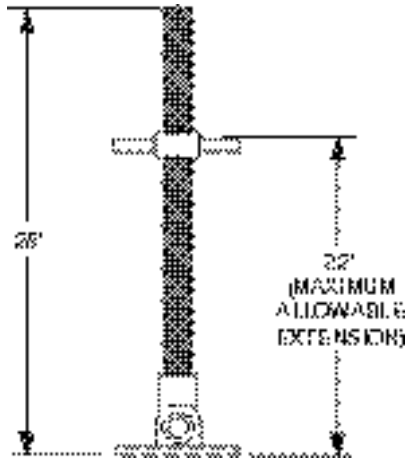

Part Number 0032-135

Weight Galv. 30 lbs.

ANCHOR HOLE SIZE AND LOCATIONS ARE NOTED ON PAGE 1 OF SECTION A

JACK ANCHORED TO SLOPED SURFACE

The swivel jack should be anchored to structure surface or restrained. Anchors, bolts or restraints must resist four times the shear force determined from the formula.

$$\text{SHEAR FORCE} = S = P \times \sin \alpha.$$

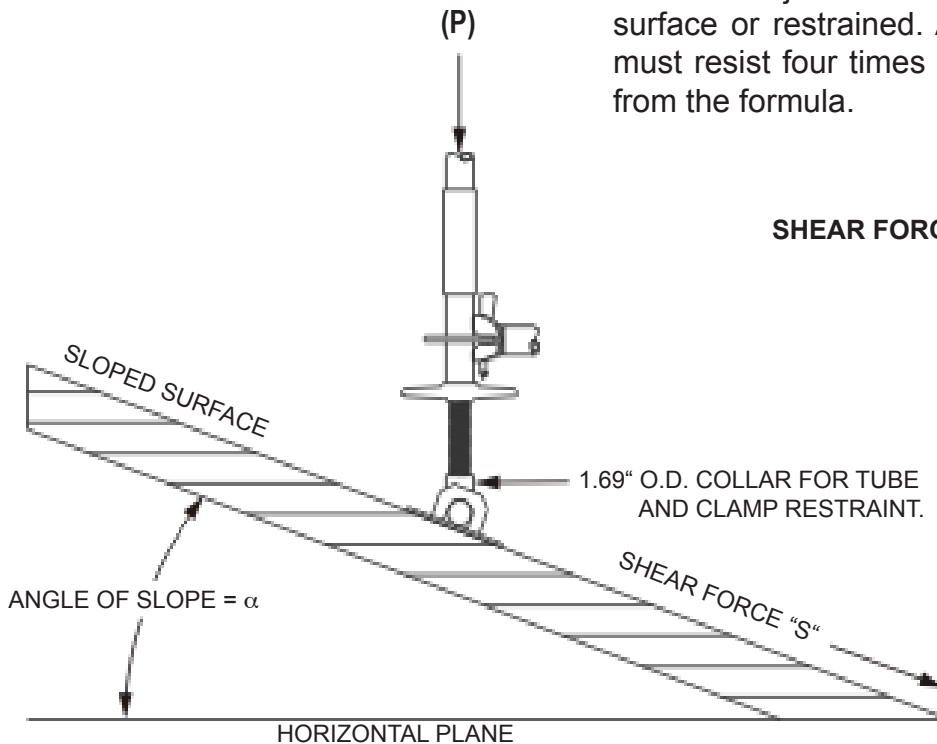

NOTE: Where angle exceeds 45°, contact Bil-Jax Application Engineering Department or use the formula $S = P \times \sin \alpha$.

Rated For Scaffold Use

Capacity of Systems Casters

Rev.

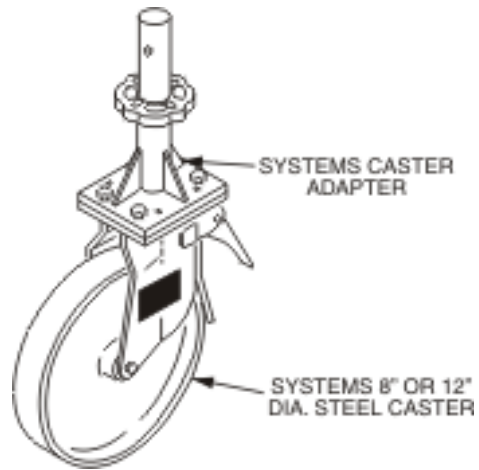

Part No.	Wheel Dia.	Wheel Style	Allowable Rolling Load
0026-001	8"	Steel	500 lbs.
0026-079	12"	Steel	900 lbs.

Rated For Scaffold Use

Capacity of Systems Vertical Standards

Rev.

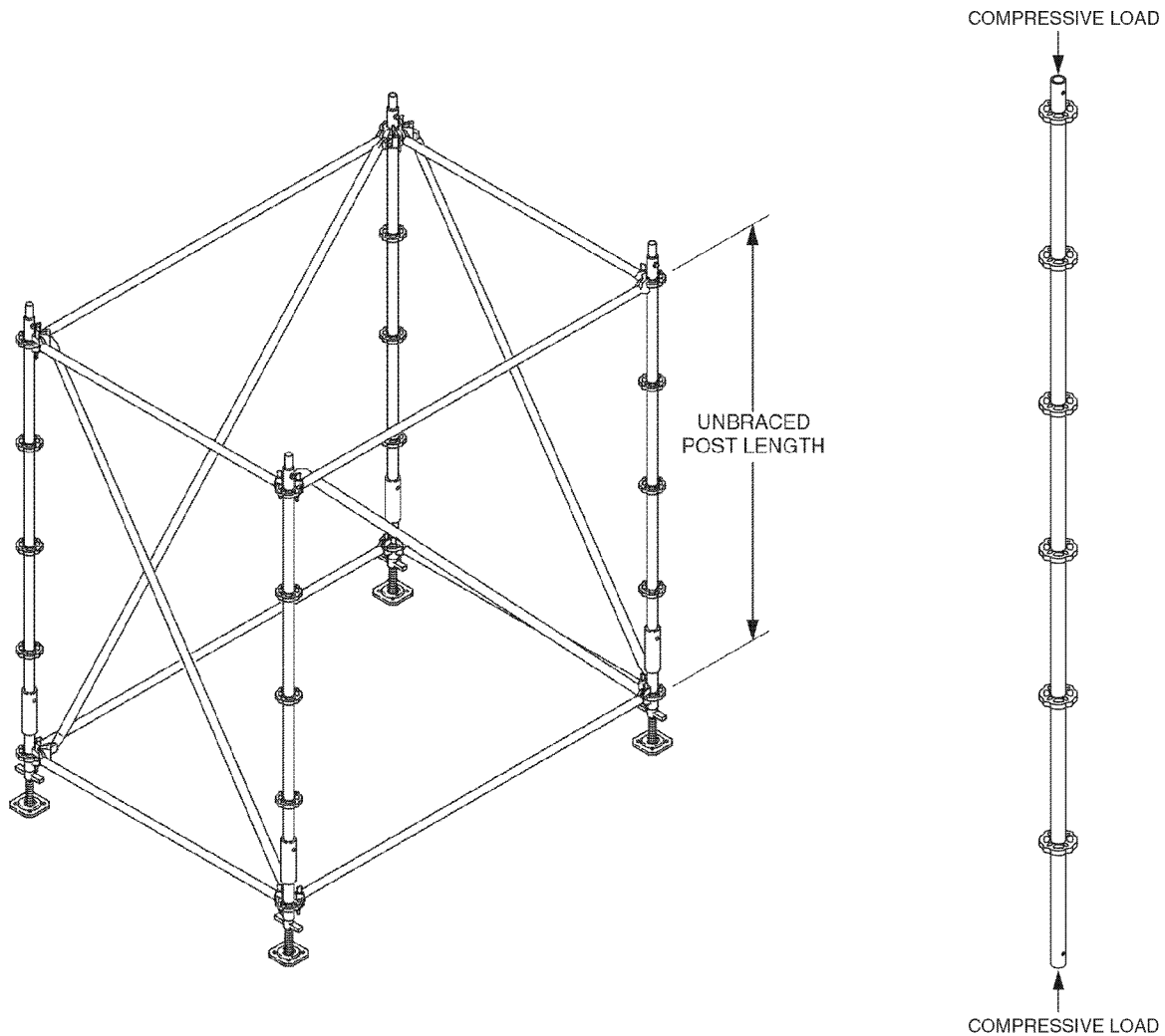

Unbraced Standard Length		Maximum Allowable Compressive Load	
Metric (m)	Imperial (in.)	Metric (kN)	Imperial (lbs.)
2.0m	78-3/4"	18kn	4,000 lbs.
1.5m	59"	20kn	4,500 lbs.
1.0m	39-3/8"	25.5kn	5,750 lbs.
0.5m	19-11/16"	33kn	7,500 lbs.

Rated For Scaffold Use

Technical Manual

Section B

Page 6 of 12

**Contur Modular Scaffold
Component Allowable Loads**

BIL-JAX[®]

Capacity of Systems Suspended Scaffold Connection

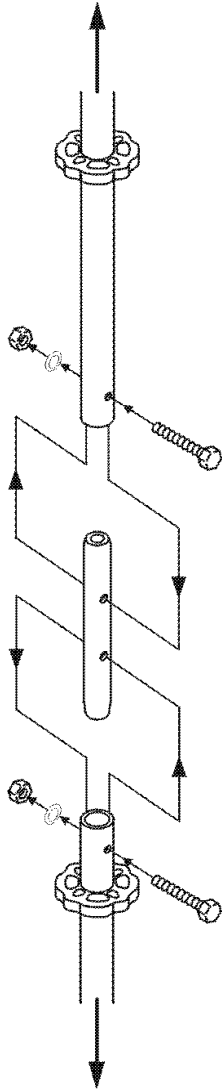

If scaffold is suspended, the coupling must be modified as follows:

Remove the system insert with spring rivet (0007-169) and replace with system insert with nut and bolt (0007-176).

Allowable Tension Loading: 3,500 lbs.

Rated For Scaffold Use

Capacity of Systems Horizontals

Rev.

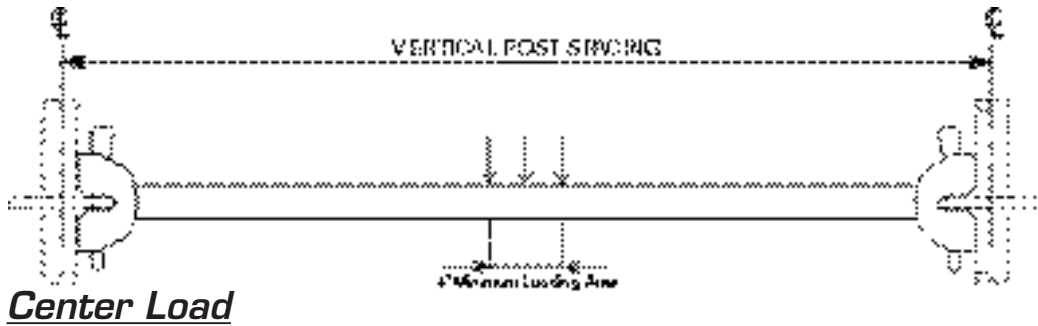

Part Number	Vertical Post Spacing	Allowable Center Load
C257-02-2024	2'	1,069 lbs.
C257-02-2036	3'	713 lbs.
C257-02-2042	3' 6"	595 lbs.
C257-02-2048	4'	534 lbs.
C257-02-2060	5'	438 lbs.
C257-02-2084	7'	315 lbs.

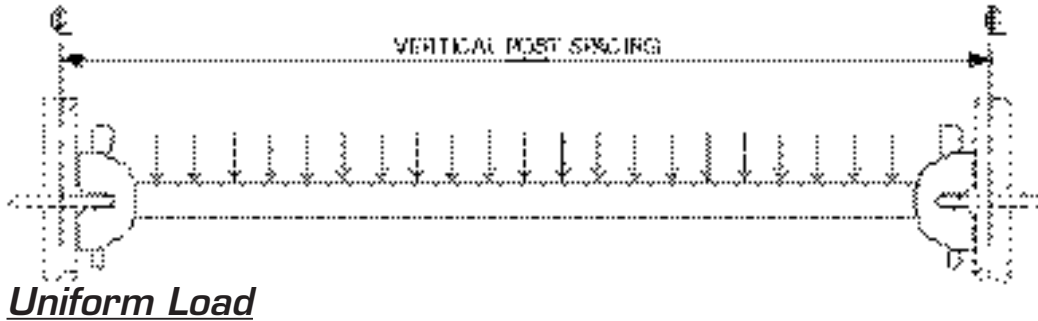

Part Number	Vertical Post Spacing	Allowable Uniform Load
C257-02-2024	2'	1,069 lbs. / ft.
C257-02-2036	3'	475 lbs. / ft.
C257-02-2042	3' 6"	349 lbs. / ft.
C257-02-2048	4'	267 lbs. / ft.
C257-02-2060	5'	175 lbs. / ft.
C257-02-2084	7'	90 lbs. / ft.

Rated For Scaffold Use

Capacity of Systems Horizontal Trusses

Rev.

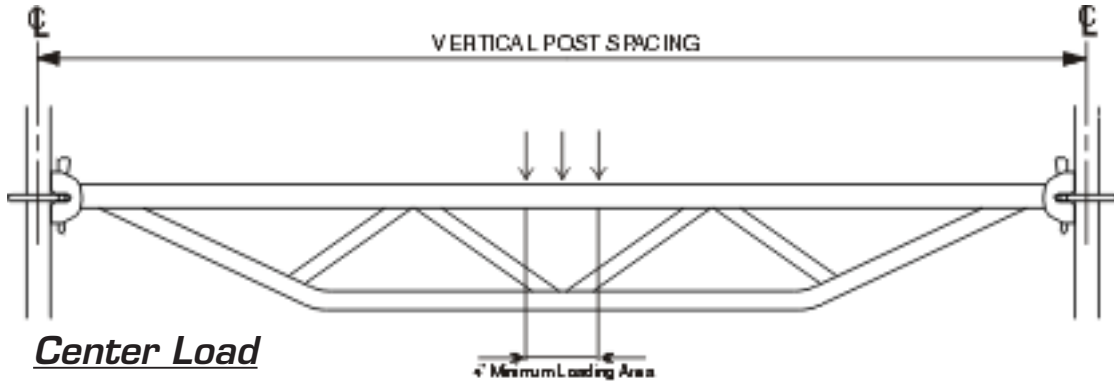

Center Load

Part Number	Vertical Post Spacing	Allowable Center Load
0257-04-2060	5'	1,405 lbs.
0257-04-2072	6'	1,344 lbs.
0257-04-2084	7'	1,295 lbs.
0257-04-2096	8'	1,160 lbs.
0257-04-2108	9'	900 lbs.
0257-04-2120	10'	690 lbs.

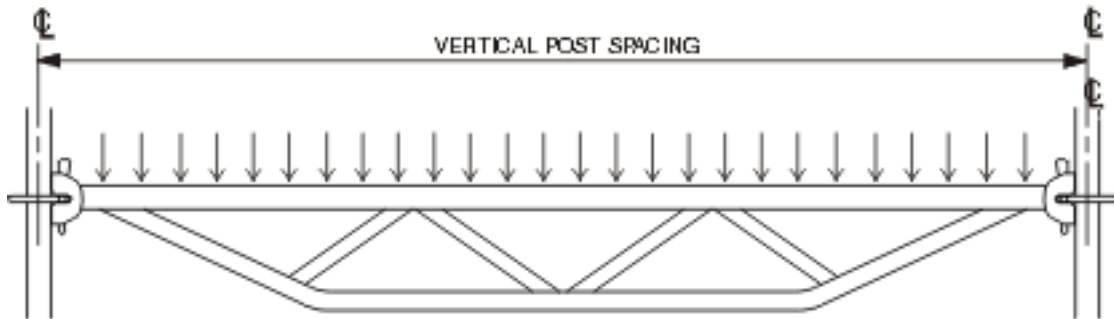

Uniform Load

Part Number	Vertical Post Spacing	Allowable Uniform Load
0257-04-2060	5'	562 lbs. / ft.
0257-04-2072	6'	448 lbs. / ft.
0257-04-2084	7'	370 lbs. / ft.
0257-04-2096	8'	290 lbs. / ft.
0257-04-2108	9'	200 lbs. / ft.
0257-04-2120	10'	138 lbs. / ft.

Rated For Scaffold Use

Capacity of Systems Lattice Girders

Rev.

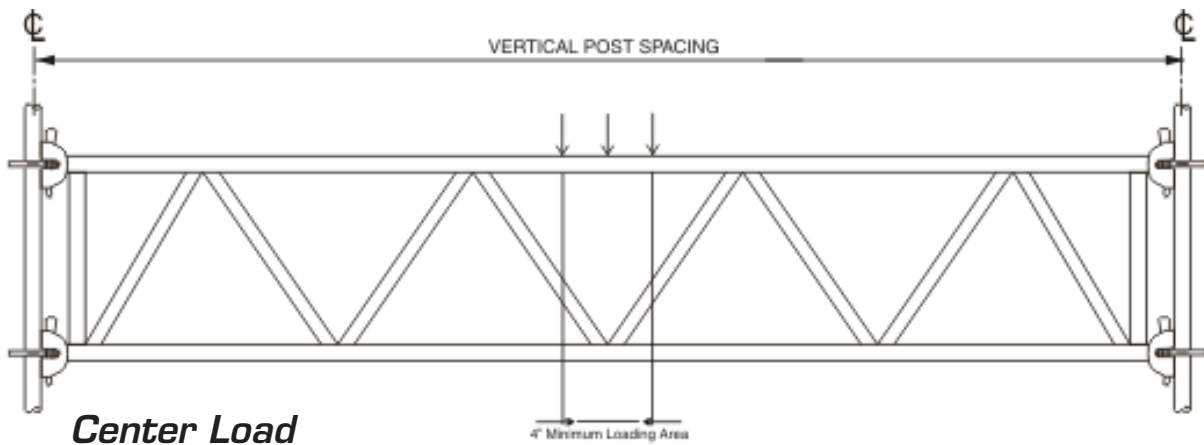

Center Load

Part Number	Vertical Post Spacing	Allowable Center Load	
		lbs.	kN
0257-23-2144	12'	2,520	11
0257-23-2168	14'	2,520	11
0257-23-2192	16'	2,060	9.0
0257-23-2216	18'	2,044	8.9
0257-23-2240	20'	2,030	8.8
0257-23-2264	22'	1,907	8.3
0257-23-2288	24'	1,784	7.8

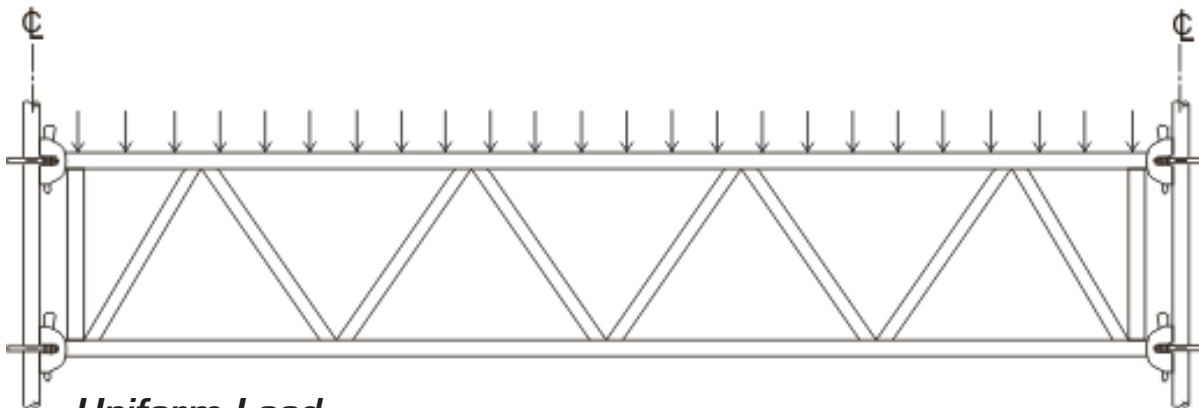

Uniform Load

Part Number	Vertical Post Spacing	Allowable Uniform Load	
		lbs./lin. ft.	kN/m
0257-23-2144	12'	292	4.20
0257-23-2168	14'	206	3.06
0257-23-2192	16'	140	2.10
0257-23-2216	18'	181	2.60
0257-23-2240	20'	139	2.10
0257-23-2264	22'	103	1.47
0257-23-2288	24'	109	1.58

NOTE: Safety Factor = 4 to 1 Based on Yield Strength

Rated For Scaffold Use

Technical Manual

Section B

Page 10 of 12

**Contur Modular Scaffold
Component Allowable Loads**

BIL-JAX[®]

Capacity of Systems Side Brackets (500 lbs. Capacity)

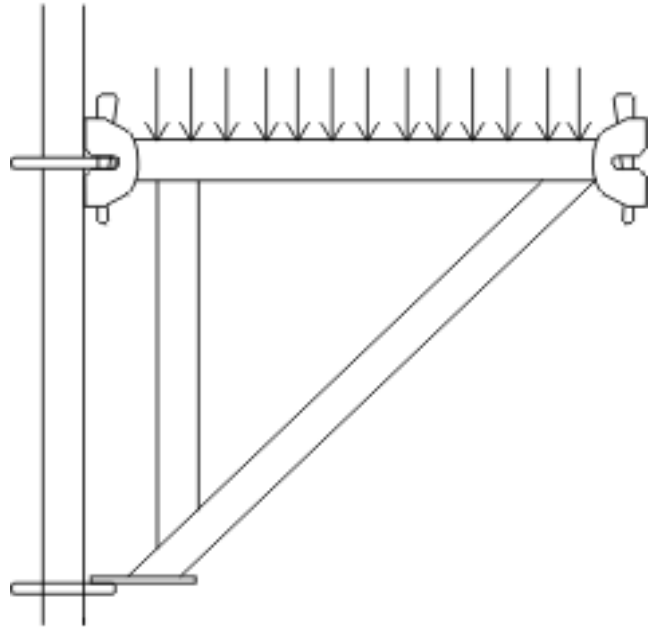
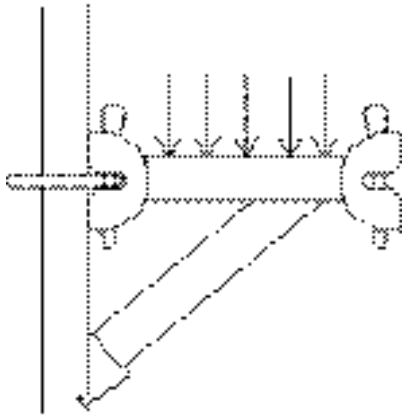

Part Number	Allowable Uniform Load
0257-07	500 lbs.
0257-08	500 lbs.
0257-09	500 lbs.

Rated For Scaffold Use

Capacity of Systems Steel Planks

Rev.

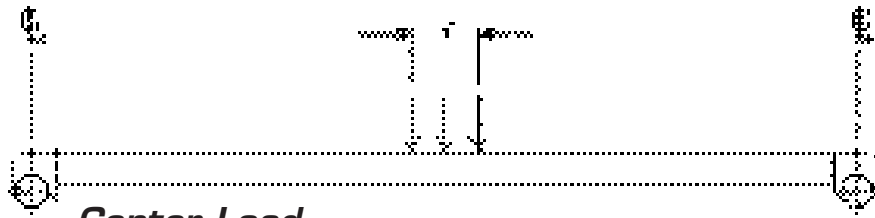

Center Load

Part Number	Effective Length	Allowable Center Load
C056-01-03	3' 0"	770 lbs.
C056-01-04	4' 0"	550 lbs.
C056-01-05	5' 0"	450 lbs.
C056-01-06	6' 0"	380 lbs.
C056-01-07	7' 0"	325 lbs.
C056-01-08	8' 0"	290 lbs.
C056-01-09	9' 0"	260 lbs.
C056-01-10	10' 0"	250 lbs.

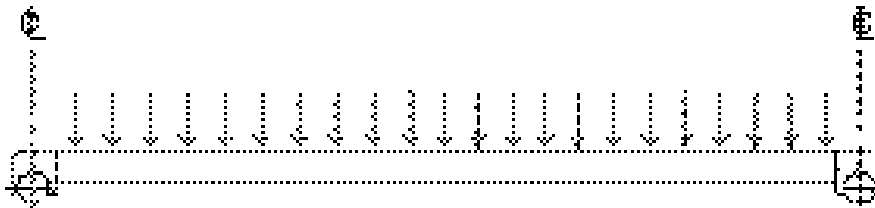

Uniform Load

Part Number	Effective Length	Allowable Uniform Distributed Load
C056-01-03	3' 0"	472 lbs. / lin. ft.
C056-01-04	4' 0"	311 lbs. / lin. ft.
C056-01-05	5' 0"	213 lbs. / lin. ft.
C056-01-06	6' 0"	150 lbs. / lin. ft.
C056-01-07	7' 0"	105 lbs. / lin. ft.
C056-01-08	8' 0"	82 lbs. / lin. ft.
C056-01-09	9' 0"	60 lbs. / lin. ft.
C056-01-10	10' 0"	49 lbs. / lin. ft.

NOTE: Allowable loads above are for 9" wide perforated plank.

Rated For Scaffold Use

Technical Manual

Section B

Page 12 of 12

**Contur Modular Scaffold
Component Allowable Loads**

BIL-JAX[®]

SECTION C

Assembly Details

SECTION C

Introduction to Assembly Details

This chapter contains illustrations of partially assembled scaffold components. The illustrations are provided as information to describe component fit and dimensional limitations. This chapter is not intended to be used as a guide for scaffold erection procedures.

Climbing Ladder Clamped to Vertical Standards

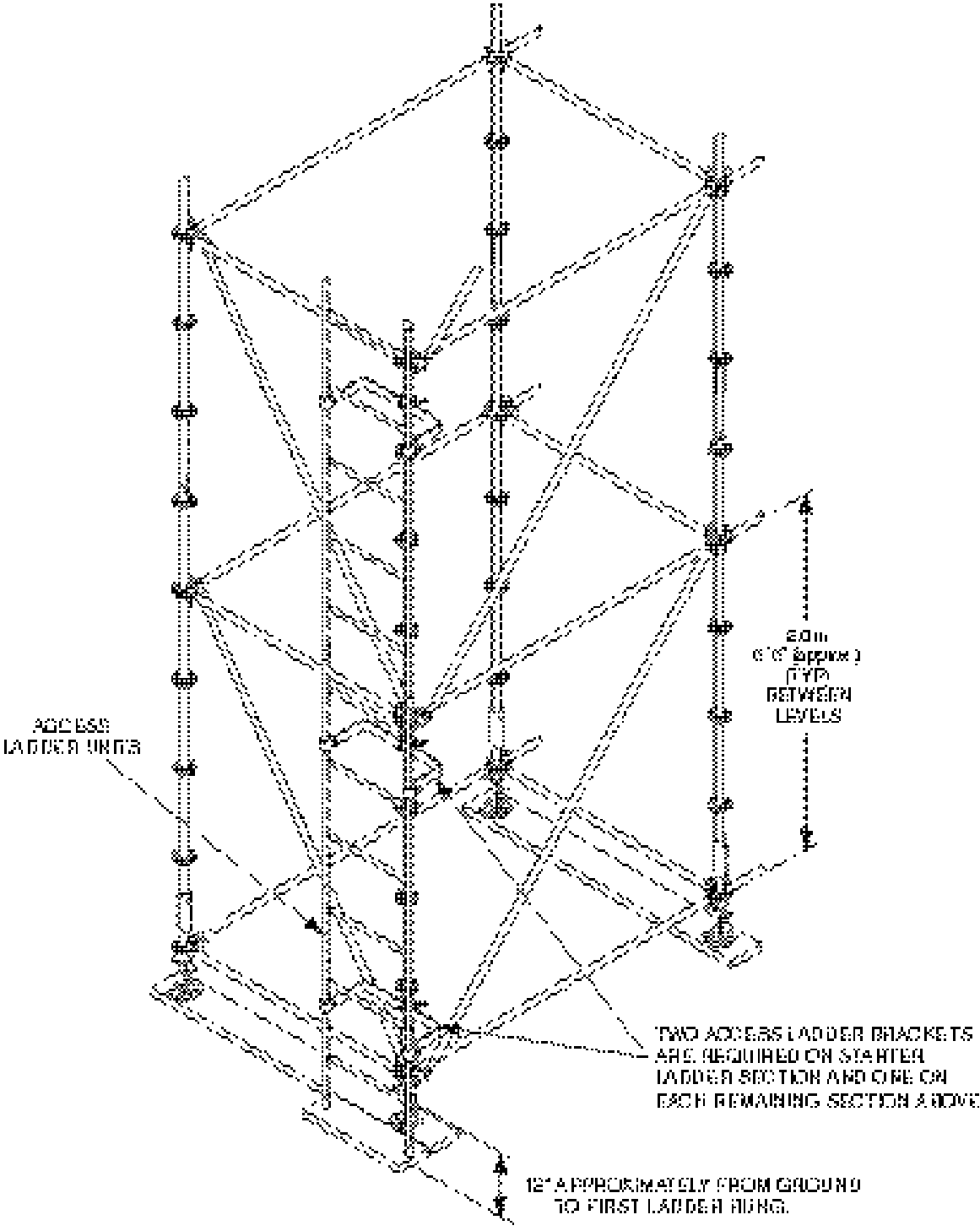

Climbing Ladder Clamped to Horizontals

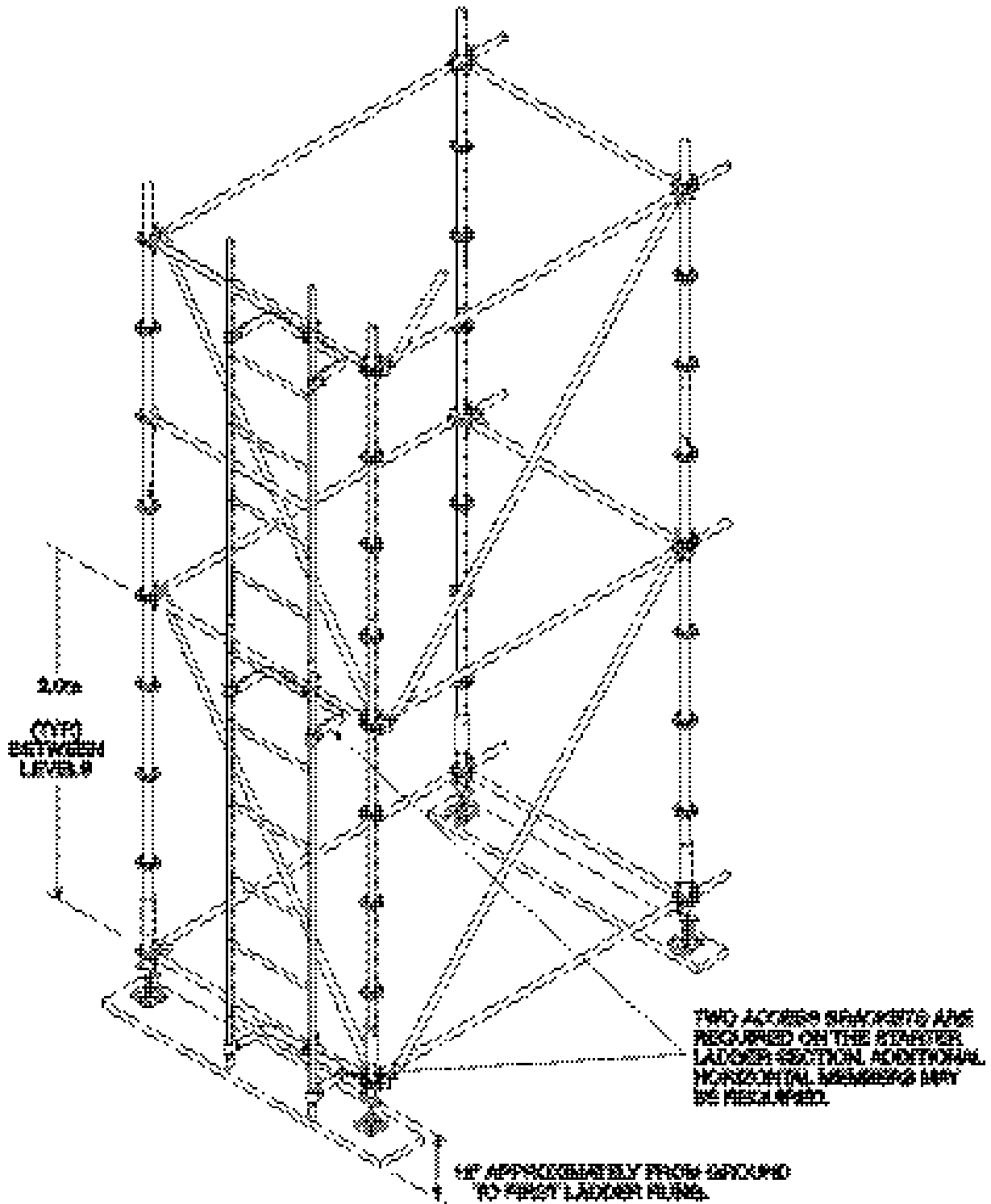

Climbing Ladder - Rest Platforms

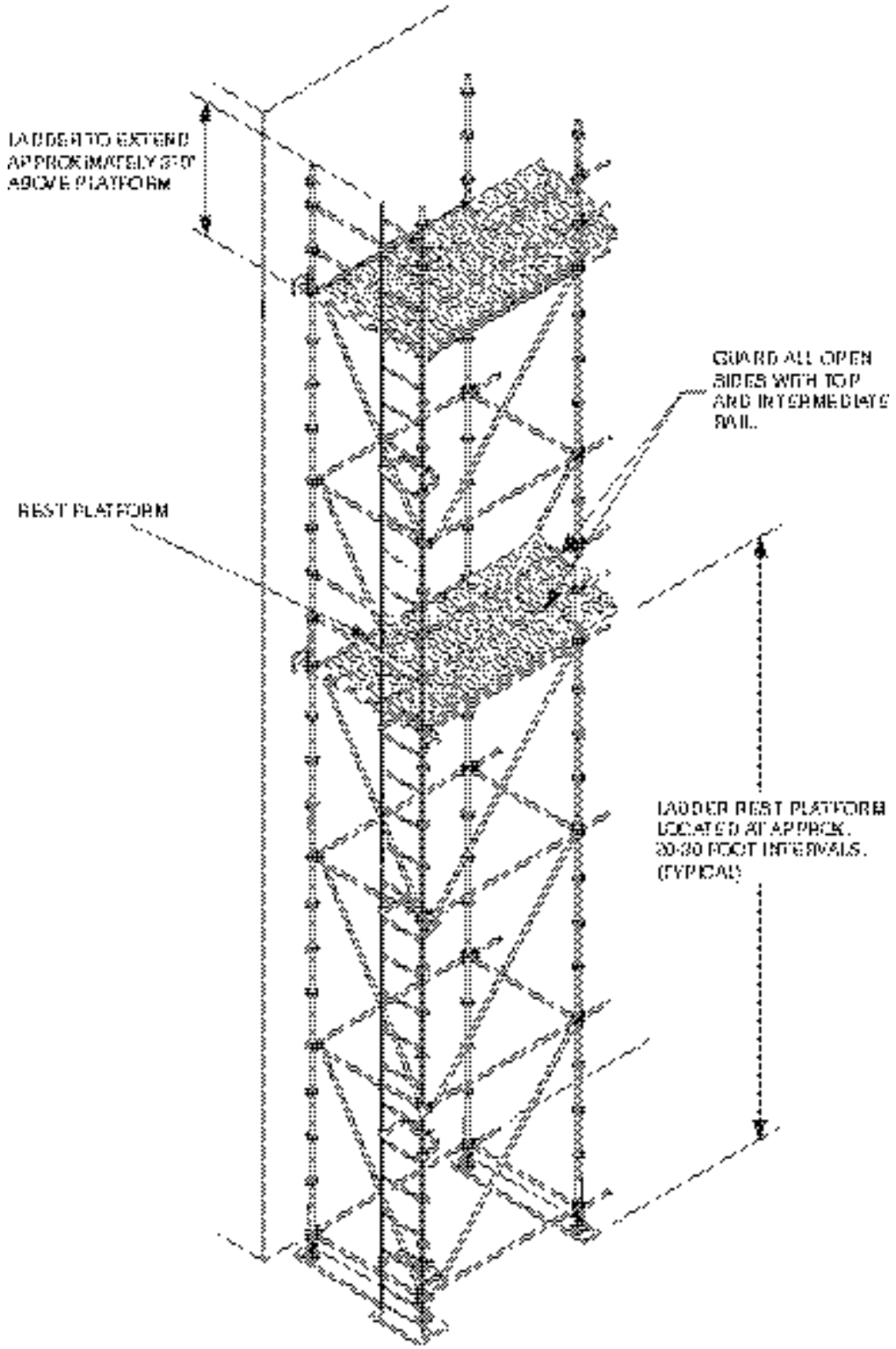

Climbing Ladder - External Landing Platforms

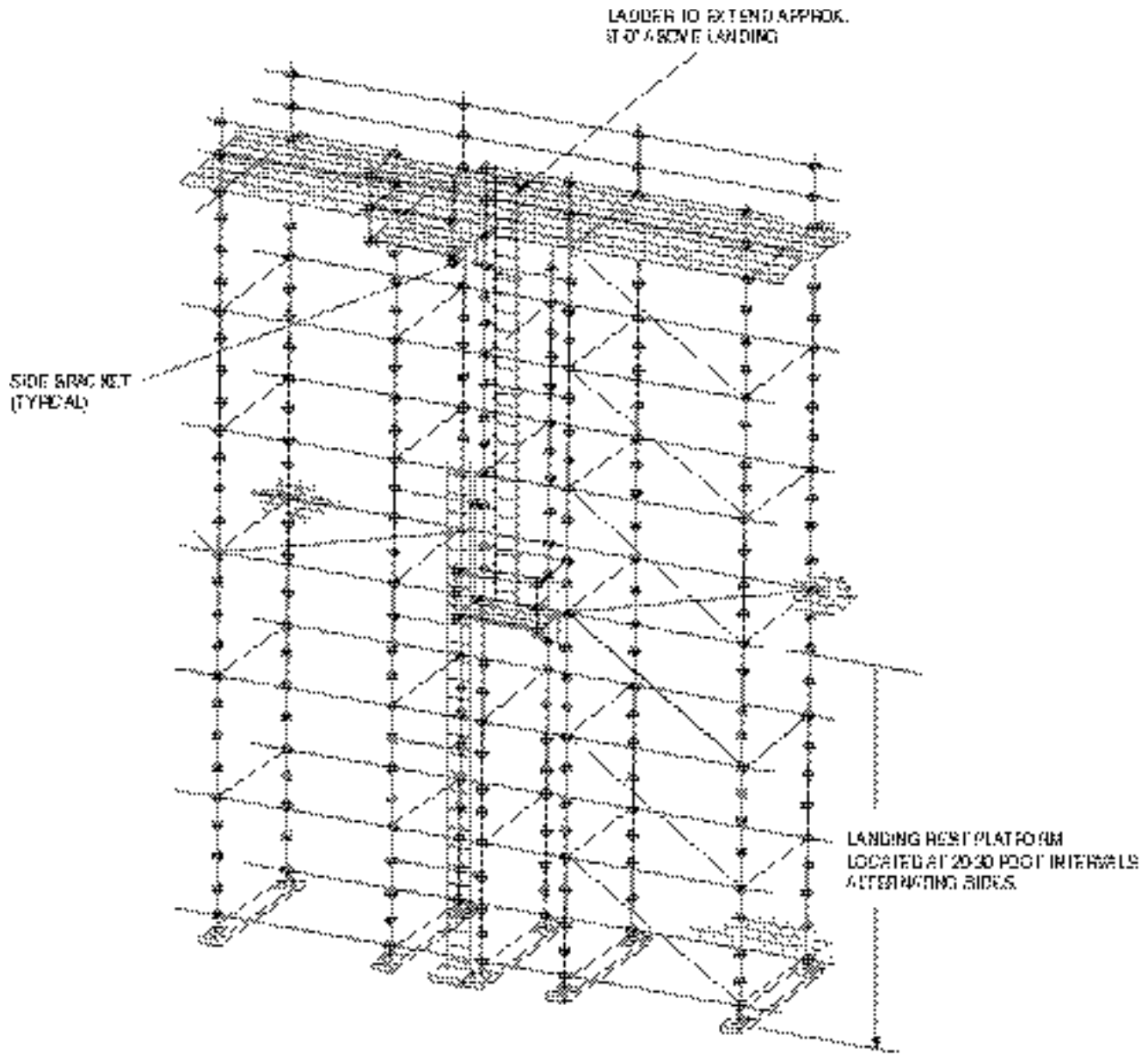

Typical Stair Tower with Post Supported Landings

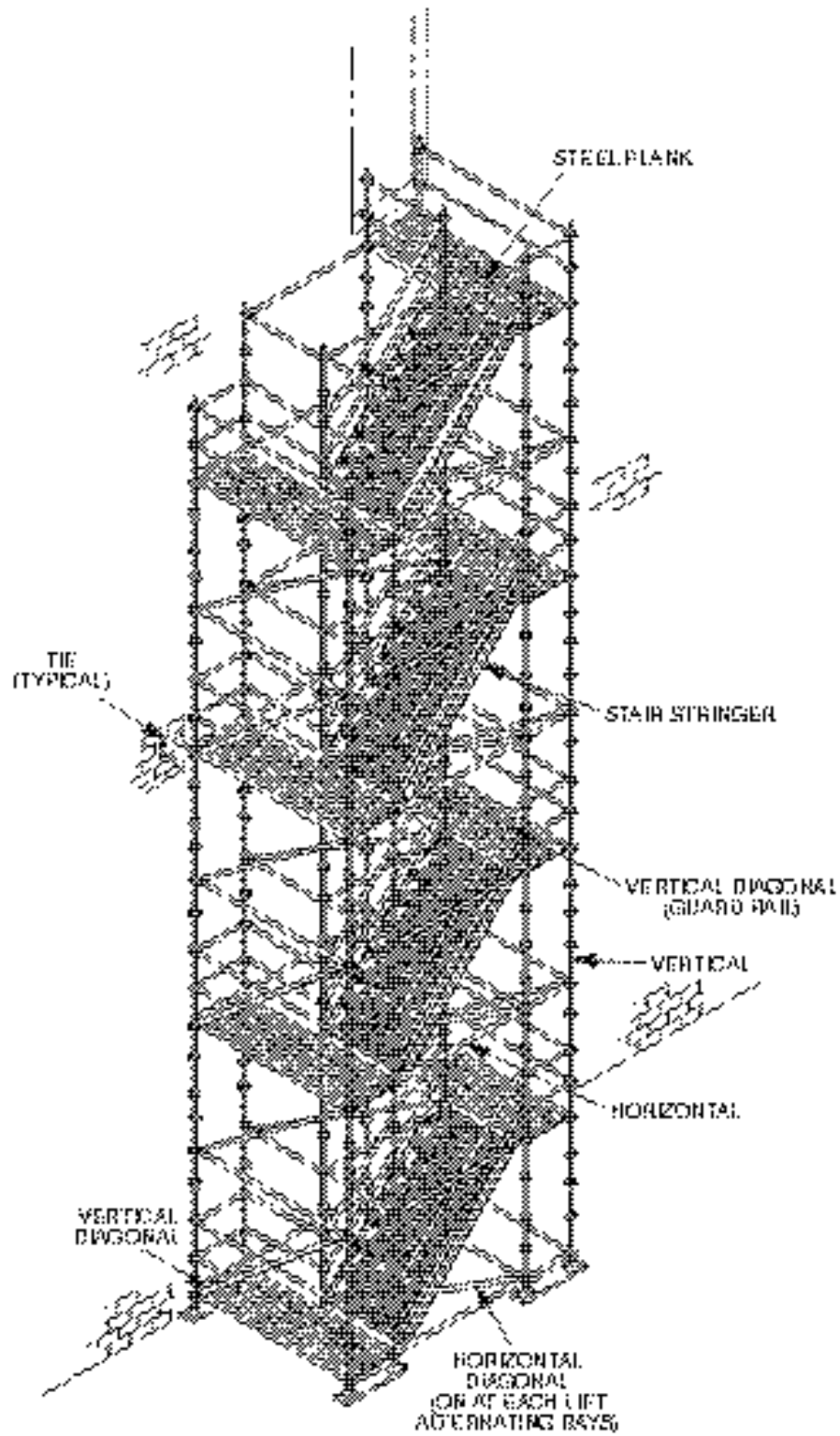

Typical Stair Tower With Side Bracket Supported Landings

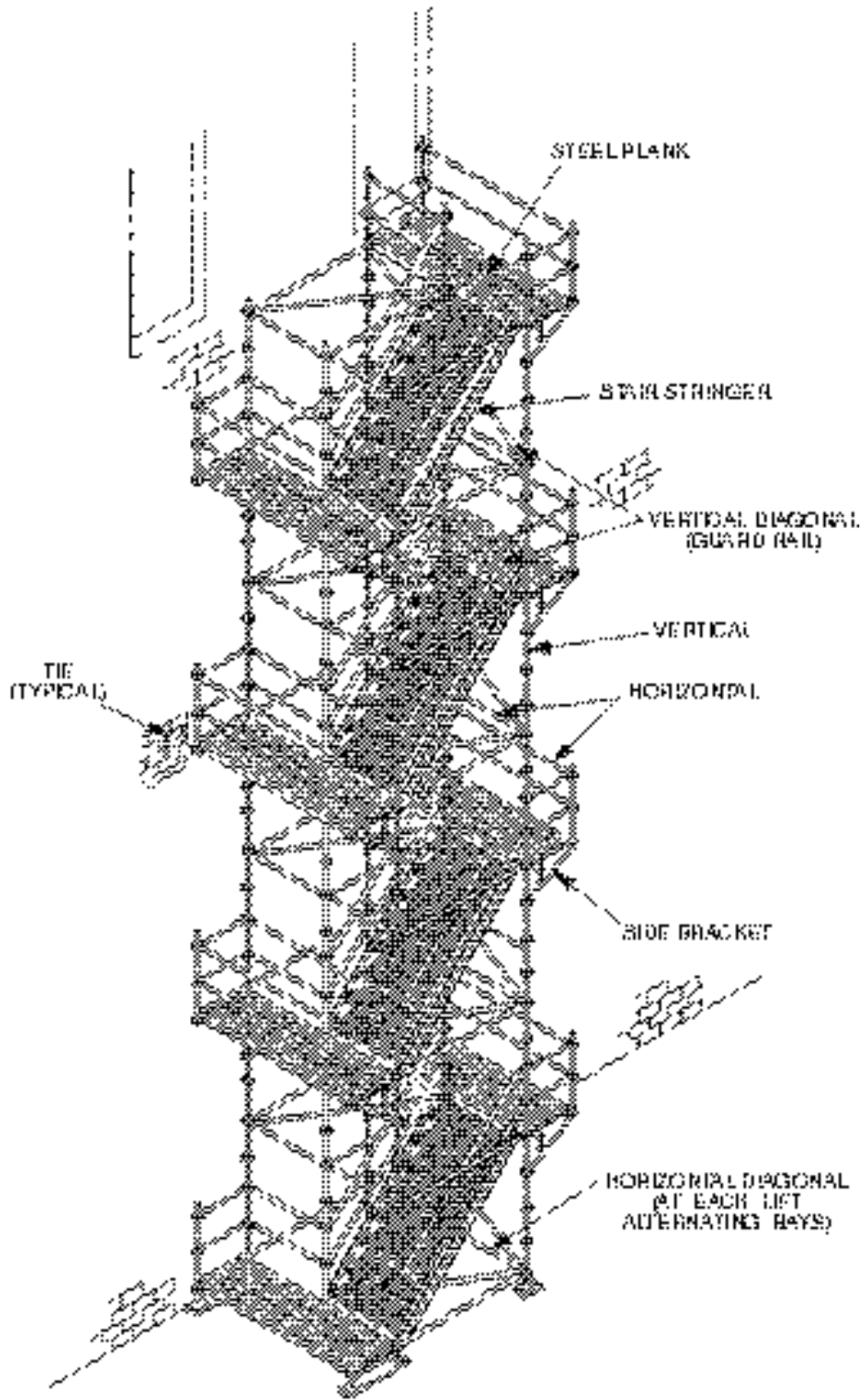

Steel Plank and Filler Chart Horizontals

9-1/2" Wide Flush Plank

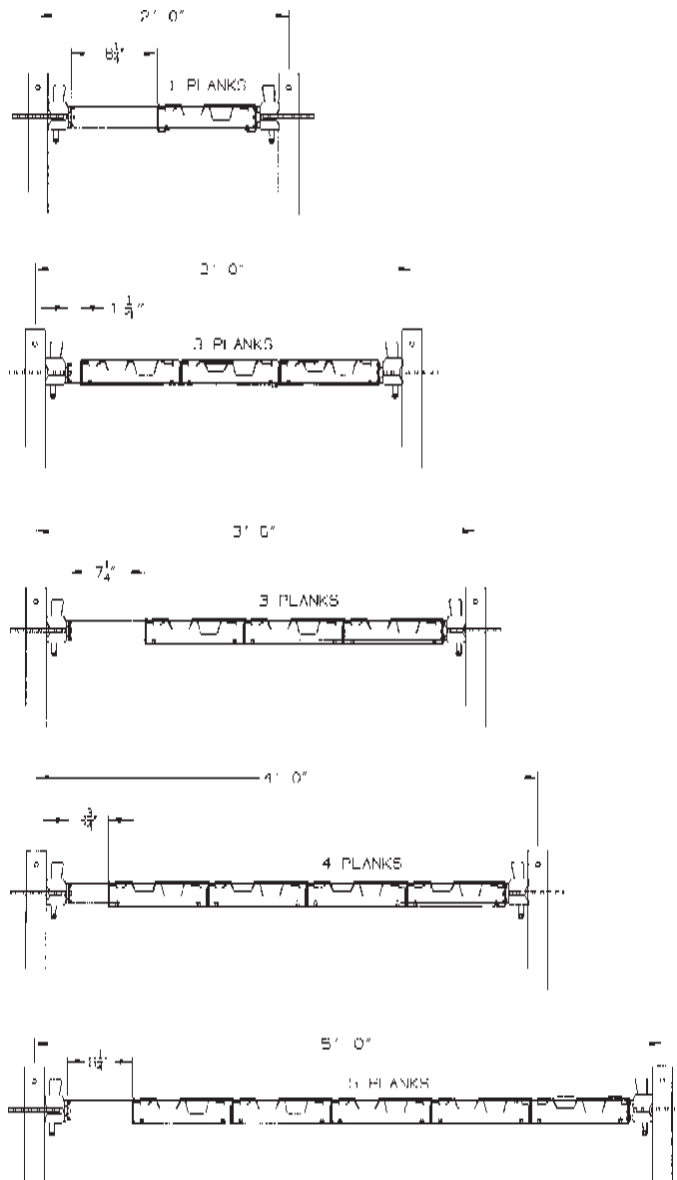

Steel Plank and Filler Chart Horizontal Trusses

9-1/2" Wide Flush Plank

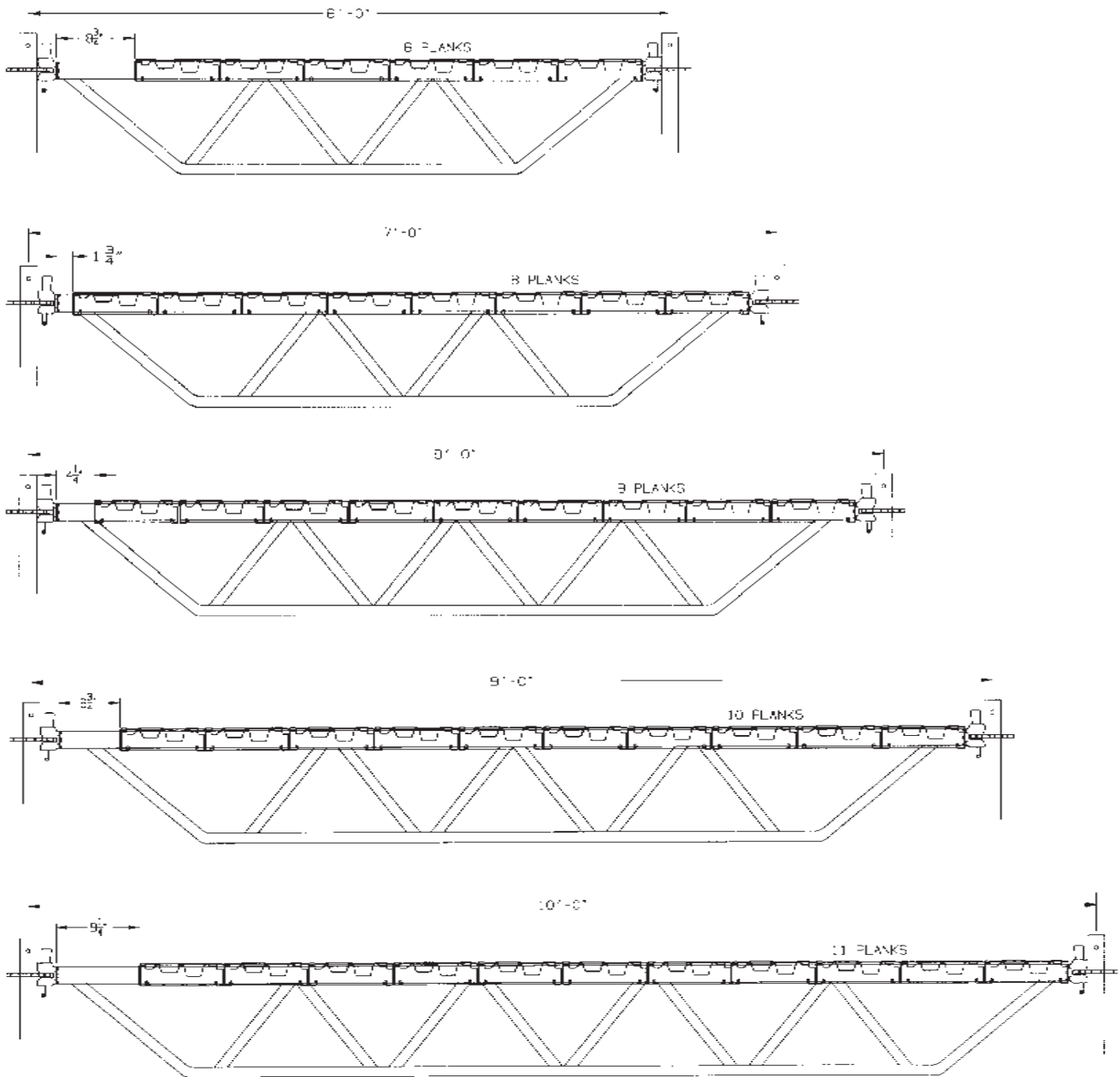

Steel Plank and Filler Chart Horizontals

9" Wide Raised Plank

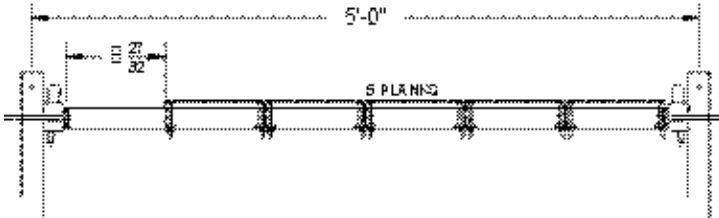
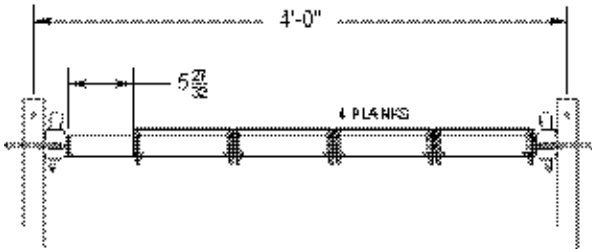
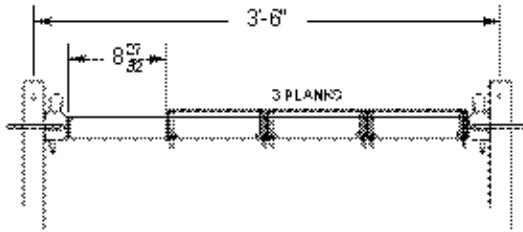
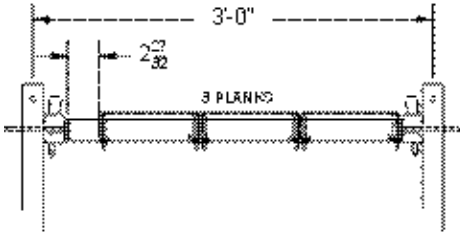
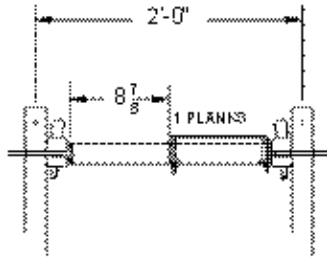

Steel Plank and Filler Chart Horizontal Trusses

9" Wide Raised Plank

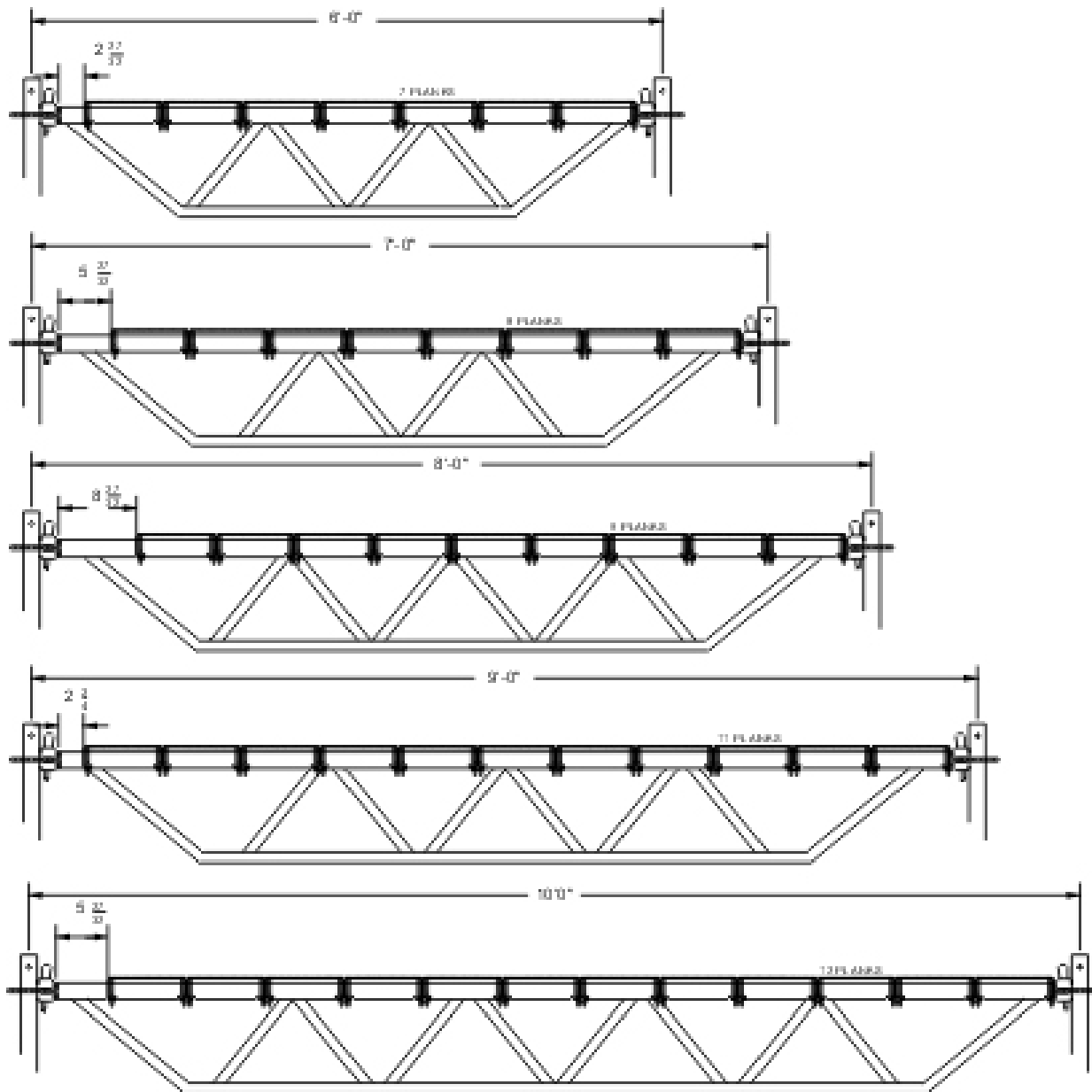

SECTION D

Tieing and Bracing

SECTION D

Introduction to Tieing and Bracing

Quantities and location of ties, guys and bracing will vary depending upon the scaffold size, weight, shape and load conditions. The following general guidelines indicate minimum bil-jax requirements and are not all inclusive. When designing scaffolds with unique configurations or special loading conditions, consult with bil-jax engineering or a professional structural engineer prior to design finalization.

NOTE:

Proper access and platform toeboards are required on all scaffolds. These items have been eliminated from the illustrations in this section for clarity purposes only.

When designing a square or rectangular scaffold, bil-jax recommends a horizontal diagonal be included in the base design. This horizontal diagonal will aid the erector in providing a square scaffold.

bil-jax tube and clamp components may be substituted for systems scaffold bracing members or horizontal diagonal members. When doing so, the load capacity of these components and their effect on the completed scaffold must be considered.

Assure ties, standoffs or guys are located at runner and bearer levels only.

Scaffolding Bracing Pattern

Rev.

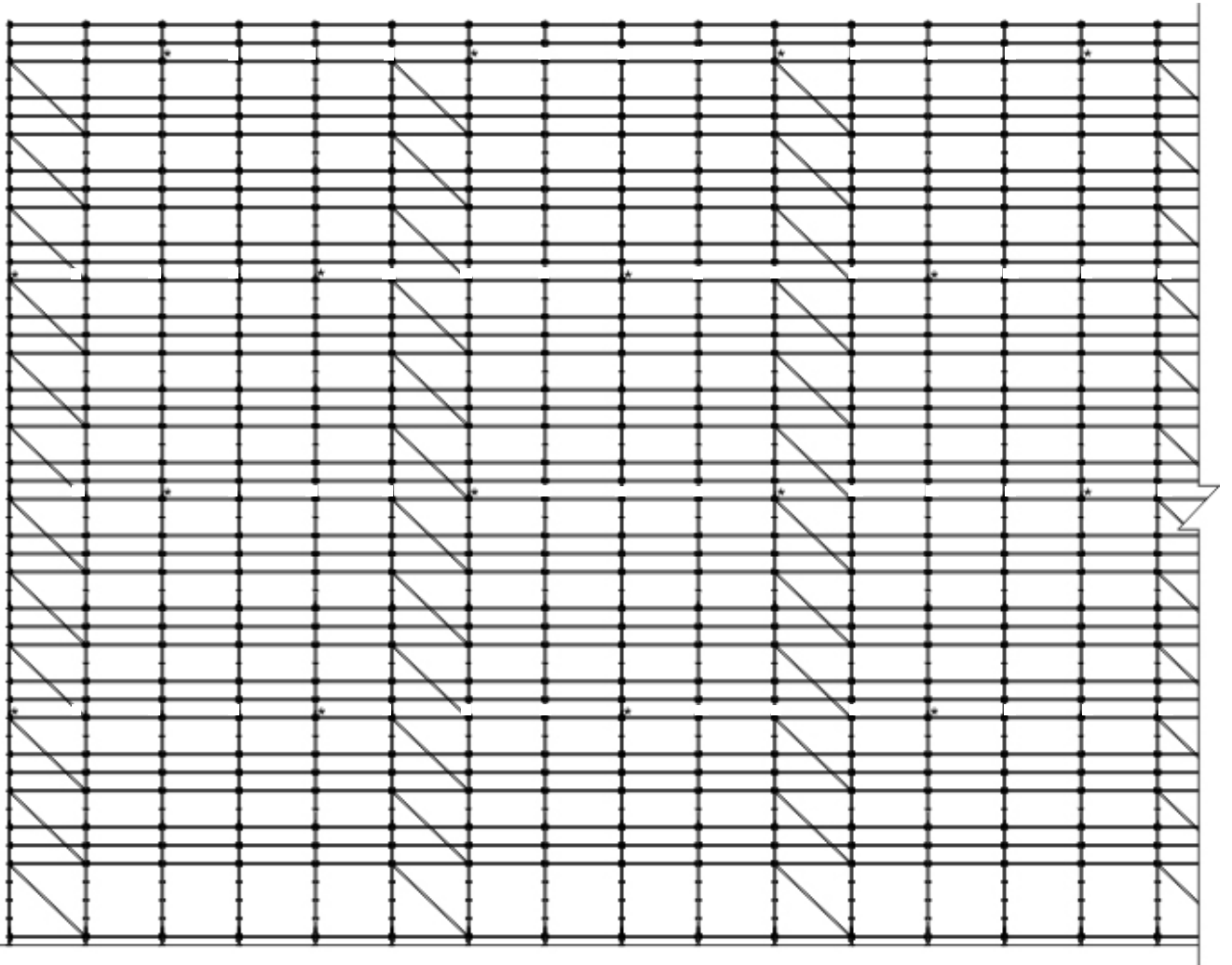

Formula for Wall Tie Location

Horizontal Distance = 28 ft. to 30 ft.

Vertical Distance = 4 times the smaller distance of your bay layout

Ex. A Scaffold setup that is 5 ft. wide by 52 ft. long by 100 ft. tall would require the following amount of wall ties:

Horizontal - $100 \text{ divided by } 28 = 3.5 \text{ (round up to } 4)$

Vertical - $4 \times 5 = 20$

Conclusion - You will need 4 wall ties horizontally every 20 ft. vertically

NOTE: When using netting or weather protection, contact Bil-Jax Application Engineering Department or a Professional Engineer

This Page Intentionally Left Blank



125 Taylor Parkway
Archbold, OH 43502
www.biljax.com